

The MRP-4424 Agent Release Control Panel

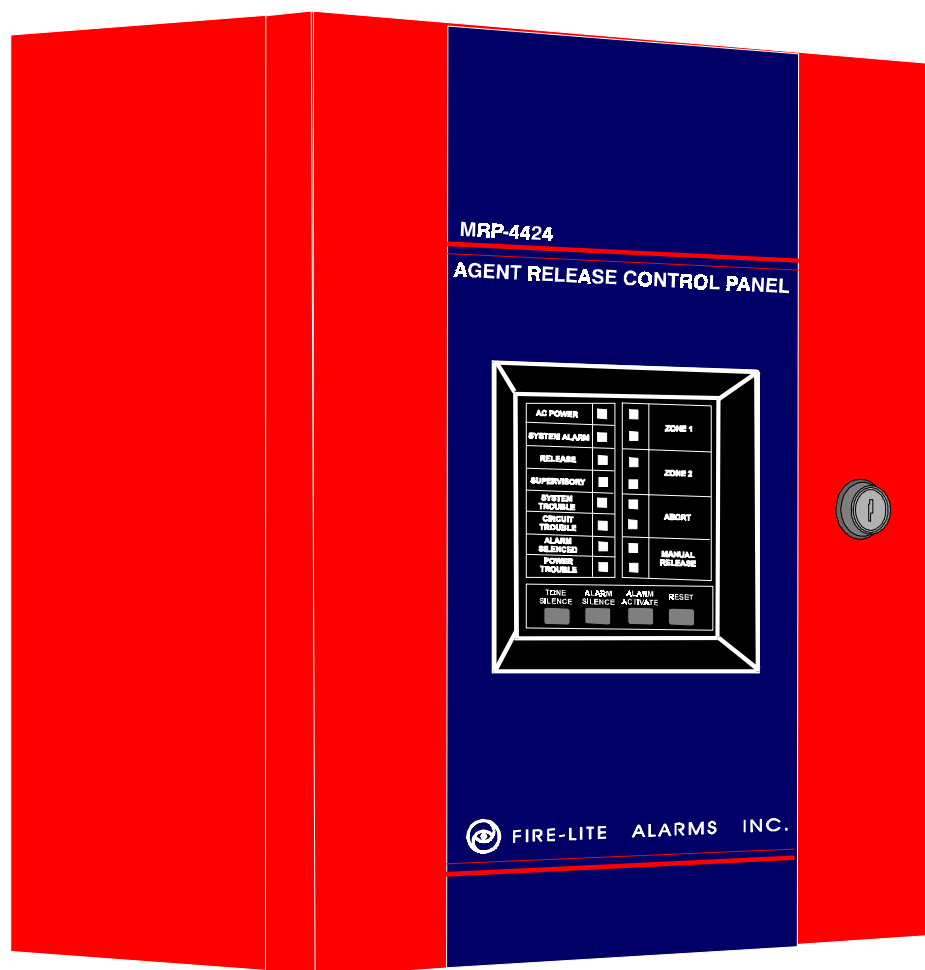

Installation Precautions - Adherence to the following will aid in problem-free installation with long-term reliability:

WARNING - Several different sources of power can be connected to the fire alarm control panel. Disconnect all sources of power before servicing. Control unit and associated equipment may be damaged by removing and/or inserting cards, modules, or interconnecting cables while the unit is energized. Do not attempt to install, service, or operate this unit until this manual is read and understood.

CAUTION - *System Reacceptance Test after Software Changes:* To ensure proper system operation, this product must be tested in accordance with NFPA 72-1993 Chapter 7 after any programming operation or change in site-specific software. Reacceptance testing is required after any change, addition or deletion of system components, or after any modification, repair or adjustment to system hardware or wiring.

All components, circuits, system operations, or software functions known to be affected by a change must be 100% tested. In addition, to ensure that other operations are not inadvertently affected, at least 10% of initiating devices that are not directly affected by the change, up to a maximum of 50 devices, must also be tested and proper system operation verified.

This system meets NFPA requirements for operation at 0-49° C/32-120° F and at a relative humidity of 85% RH (non-condensing) at 30° C/86° F. However, the useful life of the system's standby batteries and the electronic components may be adversely affected by extreme temperature ranges and humidity. Therefore, it is recommended that this system and its peripherals be installed in an environment with a nominal room temperature of 15-27° C/60-80° F.

Verify that wire sizes are adequate for all initiating and indicating device loops. Most devices cannot tolerate more than a 10% I.R. drop from the specified device voltage.

Like all solid state electronic devices, this system may operate erratically or can be damaged when subjected to lightning induced transients. Although no system is completely immune from lightning transients and interferences, proper grounding will reduce susceptibility. Overhead or outside aerial wiring is not recommended, due to an increased susceptibility to nearby lightning strikes. Consult with the Technical Services Department if any problems are anticipated or encountered.

Disconnect AC power and batteries prior to removing or inserting circuit boards. Failure to do so can damage circuits.

Remove all electronic assemblies prior to any drilling, filing, reaming, or punching of the enclosure. When possible, make all cable entries from the sides or rear. Before making modifications, verify that they will not interfere with battery, transformer, and printed circuit board location.

Do not tighten screw terminals more than 9 in-lbs. Over tightening may damage threads, resulting in reduced terminal contact pressure and difficulty with screw terminal removal.

This system contains static-sensitive components. Always ground yourself with a proper wrist strap before handling any circuits so that static charges are removed from the body. Use static suppressive packaging to protect electronic assemblies removed from the unit.

Follow the instructions in the installation, operating, and programming manuals. These instructions must be followed to avoid damage to the control panel and associated equipment. FACP operation and reliability depend upon proper installation.

Fire Alarm System Limitations

While installing a fire alarm system may make lower insurance rates possible, it is not a substitute for fire insurance!

An automatic fire alarm system - typically made up of smoke detectors, heat detectors, manual pull stations, audible warning devices, and a fire alarm control with remote notification capability can provide early warning of a developing fire. Such a system, however, does not assure protection against property damage or loss of life resulting from a fire.

Any fire alarm system may fail for a variety of reasons:

Smoke detectors may not sense fire where smoke cannot reach the detectors such as in chimneys, in walls, or roofs, or on the other side of closed doors. Smoke detectors also may not sense a fire on another level or floor of a building. A second floor detector, for example, may not sense a first floor or basement fire. Furthermore, all types of smoke detectors - both ionization and photoelectric types, have sensing limitations. No type of smoke detector can sense every kind of fire caused by carelessness and safety hazards like smoking in bed, violent explosions, escaping gas, improper storage of flammable materials, overloaded electrical circuits, children playing with matches, or arson.

IMPORTANT! Smoke detectors must be installed in the same room as the control panel and in rooms used by the system for the connection of alarm transmission wiring, communications, signaling, and/or power. If detectors are not so located, a developing fire may damage the alarm system, crippling its ability to report a fire.

FCC Warning

WARNING: This equipment generates, uses, and can radiate radio frequency energy and if not installed and used in accordance with the instruction manual, may cause interference to radio communications. It has been tested and found to comply with the limits for class A computing device pursuant to Subpart B of Part 15 of FCC Rules, which is designed to provide reasonable protection against such interference when operated in a commercial environment. Operation of this equipment in a residential area is likely to cause interference, in which case the user will be required to correct the interference at his own expense.

Audible warning devices such as bells may not alert people if these devices are located on the other side of closed or partly open doors or are located on another floor of a building.

A fire alarm system will not operate without any electrical power. If AC power fails, the system will operate from standby batteries only for a specified time.

Rate-of-Rise heat detectors may be subject to reduced sensitivity over time. For this reason, the rate-of-rise feature of each detector should be tested at least once per year by a qualified fire protection specialist.

Equipment used in the system may not be technically compatible with the control. It is essential to use only equipment listed for service with your control panel.

Telephone lines needed to transmit alarm signals from a premise to a central monitoring station may be out of service or temporarily disabled.

The most common cause of fire alarm malfunctions, however, is inadequate maintenance. All devices and system wiring should be tested and maintained by professional fire alarm installers following written procedures supplied with each device. System inspection and testing should be scheduled monthly or as required by National and/or local fire codes. Adequate written records of all inspections should be kept.

Canadian Requirements

This digital apparatus does not exceed the Class A limits for radiation noise emissions from digital apparatus set out in the Radio Interference Regulations of the Canadian Department of Communications.

Le présent appareil numérique n'émet pas de bruits radioélectriques dépassant les limites applicables aux appareils numériques de la classe A prescrites dans le Règlement sur le brouillage radioélectrique édicté par le ministère des Communications du Canada.

Table of Contents

I NFPA Standards	4
II Additional Information	4
1.0 The MRP-4424	5
1.1 Features	5
1.2 Circuits	5
1.3 Optional Boards	7
1.4 Remote Annunciator	8
1.5 Optional Meters	8
1.6 Specifications	9
2.0 System Operation	11
2.1 System Status LEDs	11
2.2 Control Switches	12
2.3 Zone Status LEDs	12
2.4 Supervisory	13
2.5 Zone Disable	13
2.6 Last Event Recall	13
3.0 Installation Procedure	14
3.1 General	14
3.2 Initiating Device Circuits	15
3.3 4-Wire Smoke Detector Connections	16
3.4 Output Circuits	17
3.5 Power	18
3.6 Optional Modules	20
3.7 Setting MRP-4424 Mode of Operation	25
Appendix A: Battery Calculations	27
Appendix B: NFPA Standard-Specific Requirements	29
Trouble Shooting Table	36

I NFPA Standards

The MRP-4424 complies with the following NFPA standards:

NFPA 12 CO₂ Extinguishing Systems (High Pressure Only)
NFPA 12A Halon 1301 Extinguishing Systems
NFPA 12B Halon 1211 Extinguishing Systems
NFPA 72-1993 Central Station Signaling Systems (Automatic, Manual, and Waterflow). Protected Premises Unit (Requires NOTI-FIRE 911A/911AC DACT or MS-5012 Slave Communicator). *
NFPA 72-1993 Local (Automatic, Manual, Waterflow and Sprinkler Supervisory) Fire Alarm Systems.
NFPA 72-1993 Auxiliary (Automatic, Manual, and Waterflow) Fire Alarm Systems. (Requires 4XTMF.)
NFPA 72-1993 Remote Station (Automatic, Manual, and Waterflow) Fire Alarm Systems. (Requires 4XTMF or NOTI•FIRE 911A/911AC DACT.) *
NFPA 72-1993 Proprietary (Automatic, Manual, and Waterflow) Fire Alarm Systems. (Requires Potter #EFT-C McCulloh Transmitter) *

** Applications which require the NOTI-FIRE 911A/911AC or the Potter EFT-C are not FM approved.*

II Additional Information

Before proceeding, the installer should be familiar with the following documents and standards:

NFPA 72 National Fire Alarm Code

Underwriters Laboratories Documents:

UL 38 Manually Actuated Signaling Boxes
UL 217 Smoke Detectors, Single and Multiple Station
UL 228 Door Closers - Holders for Fire Alarm Systems
UL 268 Smoke Detectors for Fire Alarm Systems
UL 268A Smoke Detectors for Duct Applications
UL 346 Waterflow Indicators for Fire Alarm Systems
UL 464 Audible Signaling Appliances
UL 521 Heat Detectors for Fire Alarm Systems
UL 864 Standard for Control Units for Fire Alarm Systems
UL 1481 Power Supplies for Fire Alarm Systems
UL1638 Visual Signaling Appliances
UL1971 Signaling Devices for the Hearing Impaired
CAN/ULC-S524-M91 Standard for Installation of Fire Alarms
CAN/ULC-S527-M87 Standard for Control Units for Fire Alarm Systems

Other:

NEC Article 300 Wiring Methods
NEC Article 760 Fire Alarm Systems
Applicable Local and State Building Codes
Requirements of the Local Authority Having Jurisdiction
Noti•Fire 911A Manual, Document 74-06200-005
MS-5012 Manual, Document 15465
Fire•Lite Device Compatibility Document, 15384
ADA Americans with Disabilities Act

1.0 The MRP-4424

1.1 Features

- Microprocessor-controlled
- Power-limited on all circuits except Municipal Box output
- Alarm and trouble resound
- Four Style B/D Initiating Device Circuits
- Two Style Y/Z Notification Appliance Circuits
- Two Style Y Release Circuits
- General alarm and trouble relays
- Optional module for 4 zone/function relays (4XZMF)
- Optional transmitter module (4XTMF). Complies with NFPA 72-1993 Auxiliary and Remote Station Fire Alarm Systems
- Optional volt/amp meter module (4XMMF)
- Optional supervised remote annunciator (RZA-4XF)
- Requires LED Interface Module (4XLMF)
- Optional digital communicator (NOTI•FIRE 911A/911AC)*
- Complies with NFPA 72-1993 Central Station and NFPA 72-1993 Remote Station Fire Alarm Systems
- Supervisory Input Option
- Complies with NFPA 72-1993 Proprietary Fire Alarm System. (requires Potter #EFT-C McCulloh Transmitter)
- Designed for suppression standards NFPA 12, 12A, and 12B
- Disable/enable controls per Initiating Device Circuits
- Last Event Recall
- Battery/Earth fault supervision
- Fuse protection on all Notification/Release Circuits
- RMS regulated output power, 2.25 amps
- 7 amp/hour to 15 amp/hour battery options, up to 90 hours standby
- Resettable and non-resettable regulated power outputs
- Extensive transient protection
- Watchdog timer to supervise microprocessor (includes MICRO FAIL LED)
- Output circuits protected against false activations
- Slide-in zone identification labels
- Steel cabinet 14.5" wide by 16" high by 5" deep
- Dead-front dress panel option (DP-4XF)
- Trim ring for flush mount between 16" center studs (TR-4XRF)
- Abort and manual release circuits
- Cross-zone option
- Delay timer (adjustable)
- Three abort function options

* Applications which require the NOTI-FIRE 911A/911AC or Potter EFT-C are not FM approved.

1.2 Circuits

Input Circuits

Detector Zone 1 (Style B/D)

Detector Zone 2 (Style B/D)

Abort (Style B/D)

Manual Release (Style B/D)

Output circuits - optional auxiliary relay module (4XZMF) tracks these four circuits.

Notification Appliance Circuit 1 (Style Y/Z)

Notification Appliance Circuit 2 (Style Y/Z)

Releasing Circuit 1 (Style Y)

Releasing Circuit 2 (Style Y)/Supervisory Input (Style B)

Front Panel Control Switches

Switch 1 Tone Silence

Switch 2 Alarm Silence

Switch 3 Alarm Activate

Switch 4 System Reset

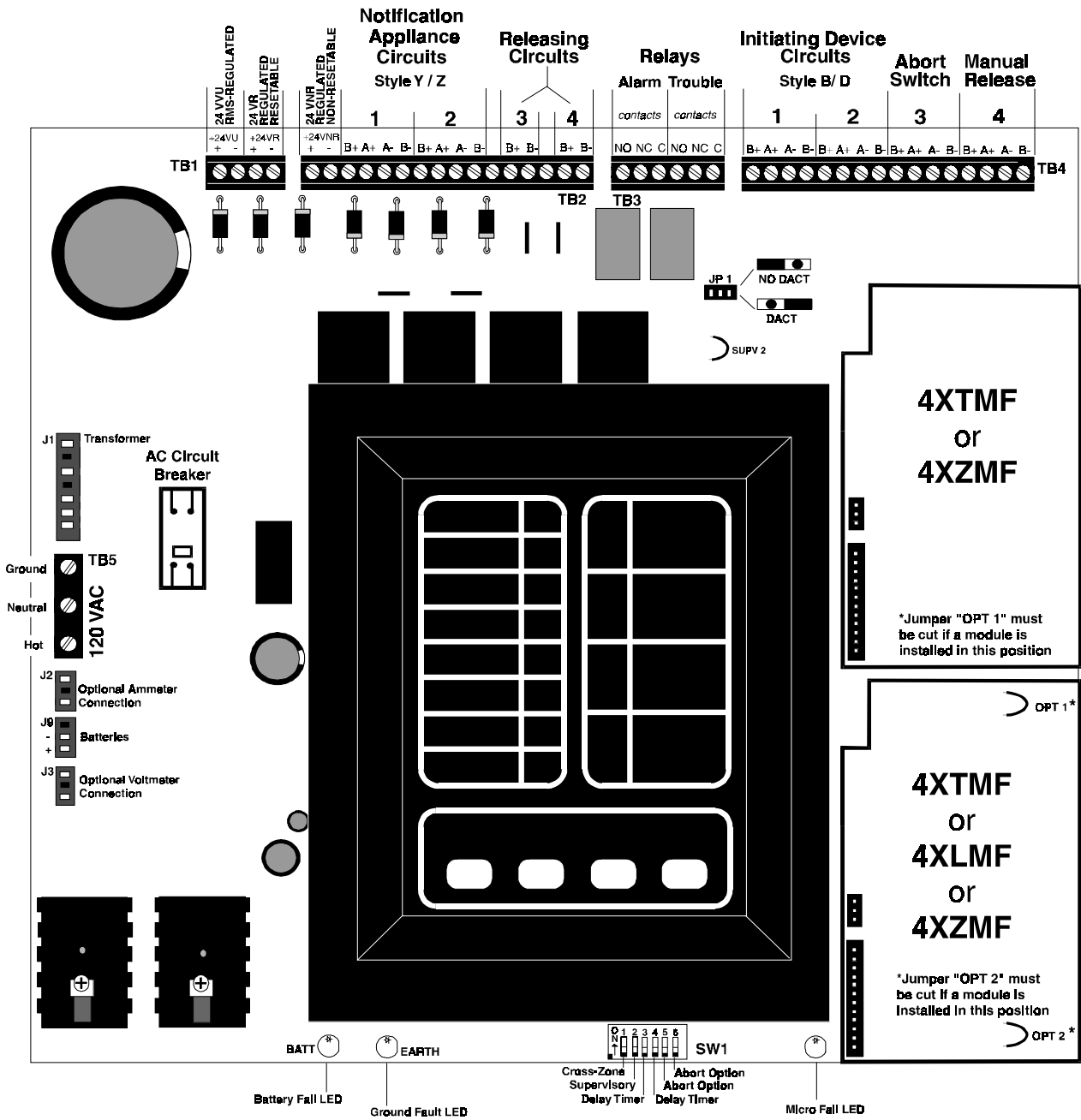

Figure 1.0-1: MRP-4424 Installation Diagram

1.3 Optional Boards

The MRP-4424 has mounting slots for two option boards. Any two of the following three option modules may be installed.

Transmitter Module (4XTMF)

The Transmitter Module provides a supervised output for local energy municipal box transmitter (for NFPA 72-1993 Auxiliary Fire Alarm System) and alarm and trouble reverse polarity circuits (for NFPA 72-1993 Remote Station Fire Alarm System). Also included is a DISABLE switch and disable trouble LED.

As a jumper option, the alarm reverse polarity circuit will open on trouble if no alarm exists.

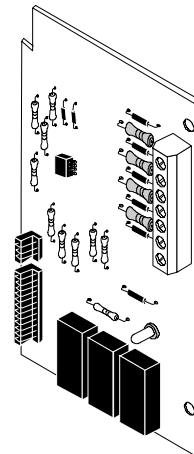

LED Interface Module (4XLMF)

The LED Interface Module supports the RZA-4XF Remote Annunciator module. Annunciator wiring is supervised for open conditions by this module. The Annunciator Driver Module mounts to the main board, occupying one of the two option connectors.

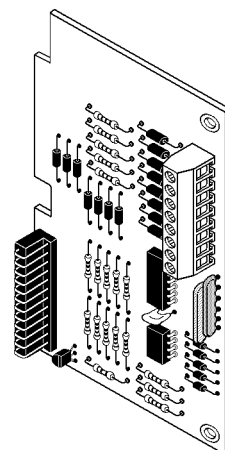

Zone Relay Module (4XZMF)

The Zone Relay module provides Form-C contacts for the following:

As a jumper option, the first four relays described below can be made silenceable.

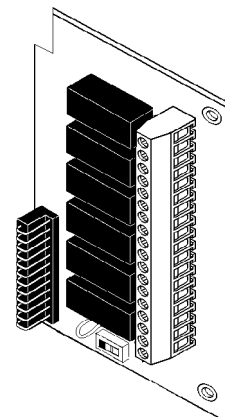

DIP 1=OFF Either Zone	DIP 1=ON Cross Zone	If Supervisory (DIP 2=ON)	
		Either Zone	Cross Zone
Alarm Detected	First Alarm	Alarm Detected	First Alarm
Alarm Detected	Second Alarm	Alarm Detected	Second Alarm
Release 1	Release 1	Release	Release
Release 2	Release 2	Not Used	Not Used

Transmitter Module (4XTMF)

For Local Energy Municipal Box service (NFPA 72-1993 Auxiliary Fire Alarm System):

Supervisory current: 5.0 mA.

Trip current: 0.35 amps. (Subtracted from Notification Appliance power.)

Coil Voltage: 3.65 VDC.

Coil resistance: 14.6 ohms.

Maximum allowable wire resistance between panel and trip coil: 3 ohms

Municipal Box wiring can leave the building.

For Remote Station service (NFPA 72-1993 Remote Station Fire Alarm System):

Maximum load for each circuit: 10 mA.

Reverse polarity output voltage: 24 VDC.

Remote Alarm and Remote Trouble wiring can leave the building.

LED Interface Module (4XLMF)

Maximum voltage/current, each output: 27.6V/8mA.

Note: Outputs are power limited.

Zone Relay Module (4XZMF)

Dry Form-C contacts rated: 2.0 amps @ 30 VDC (resistive), 0.5 amps @ 30 VAC (resistive)

1.4 Remote Annunciator

Notifier Remote Annunciator (RZA-4XF)

The Remote Annunciator mounts on a standard single-gang box, and provides LED indication of the same functions as the zone relay module. For example, with DIP 1=ON and DIP 2=OFF:

- One Zone in Alarm (red)
- Two Zones in Alarm (red)
- Releasing Circuit 1 (red)
- Releasing Circuit 2 (red)
- System Trouble (yellow)

A Local Trouble Sounder and Silence Switch are also provided. All LED wiring is supervised for open conditions. Any open condition will cause the System Trouble LED to illuminate.

Note: The Remote Annunciator requires the use of an LED Interface module (4XLMF).

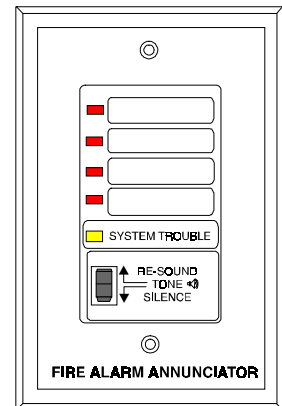

1.5 Optional Meters

Voltage, Current Meters (4XMMF)

The Meter Module provides a voltmeter to measure the voltage across the batteries and an ammeter to measure the charging current to the batteries. The meters are provided as a assembly that mounts to the lower left-hand corner of the cabinet.

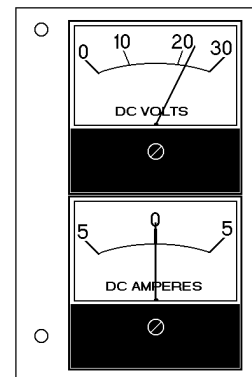

1.6 Specifications

AC Power

120 VAC, 50/60 Hz, 1.2 amps
Wire size: minimum #14 AWG with 600V insulation

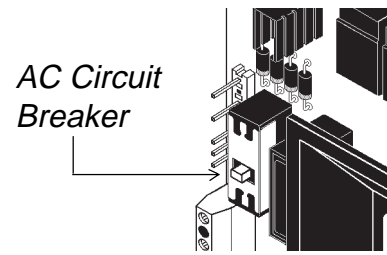

Battery (lead acid only)

Maximum Charging Circuit: 27.6V, 1.5 amps
Maximum Battery Capacity: 15 AH. (Batteries larger than 12 AH require Fire•Lite BB-17F or other UL listed external battery cabinet.)

Initiating Device Circuits - four total

Power-limited circuitry
Operation: Style B/D
Normal Operating Voltage: 24 VDC (ripple = 1.0V peak-to-peak)
Alarm current: 15 mA minimum
Short circuit current: 40 mA maximum
Maximum detector current in standby: 2 mA (max) per zone
Maximum loop resistance: 200 ohms
End-of-line resistor: 4.7K, 1/2-Watt (part # 71252UL listed)
Detector loop current is sufficient to ensure operation of one alarmed detector per zone.
Supervisory current: 5 mA (including end-of-line resistor)

Notification Appliance and Releasing Circuits - four total

Power-limited circuitry
Operation: two Style Y/Z NACs
two Style Y Releasing Circuits
Maximum allowable voltage drop due to wiring: 2 VDC
Normal Operating Voltage: 24 VDC
Total current available to all external devices: 2.25 amps.

Maximum signaling current per circuit: 1.5 amps
End-of-line resistor: 4.7K, 1/2-Watt (part # 71252UL listed)

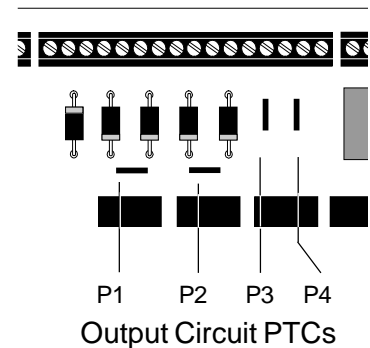

Alarm and Trouble Relays

Dry Form-C contacts rated: 2.0 amps @ 30 VDC (resistive), 0.5 amps @ 30 VAC (resistive). All relays must be connected to a power limited power supply.

Four-wire Smoke Detector Power

Up to 200 mA is available for powering 4-wire smoke detectors.
Maximum ripple voltage: 1.0 V p/p

Non-resettable Power

Total DC current available from this output is up to 200 mA (subtracted from 4-wire smoke power).
Maximum ripple voltage: 1.0 V p/p

RMS Regulated Power

Total DC current available for powering external devices is 0.5 amp (subtracted from 2.25 amps available to notification appliance circuits).
Maximum ripple voltage: 100 mV p/p

Note: For device compatibility, refer to the Device Compatibility Chart, Document 15384.

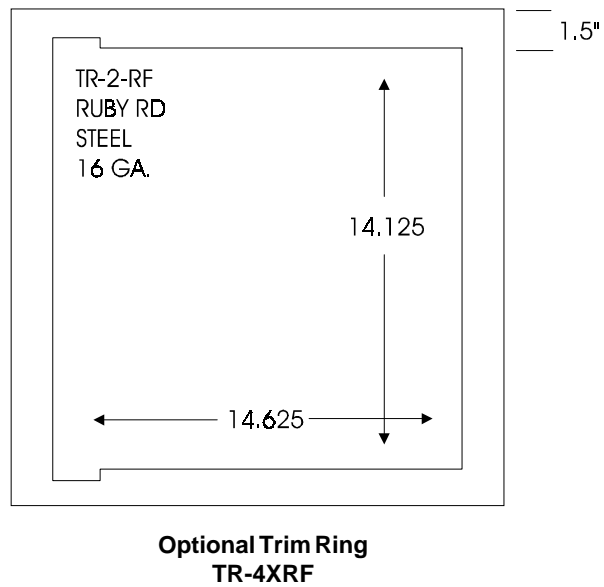
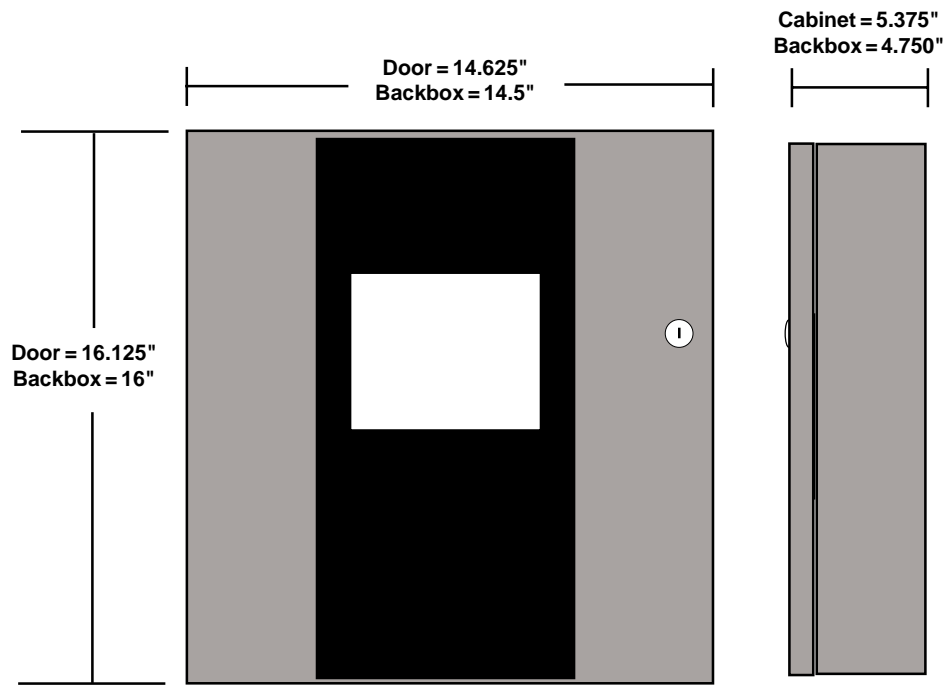

Figure 1.6-1: Cabinet Dimensions

2.0 System Operation

2.1 System Status LEDs

Alarm, Trouble and Supervisory LEDs will flash on and off until the event(s) has been acknowledged (TONE or ALARM SILENCE), at which point the LED will illuminate steadily.

AC POWER

Green LED that illuminates steadily to indicate presence of AC power.

SYSTEM ALARM

Red LED that flashes when an alarm occurs.

RELEASE

Red LED that illuminates steadily when release occurs.

SUPERVISORY

Yellow LED that flashes upon activation of a supervisory device (such as tamper switch) on Output 4 if selected (see section 3.7).

SYSTEM TROUBLE

Yellow LED that flashes for any trouble condition, including those associated with option boards.

CIRCUIT TROUBLE

Yellow LED that flashes for trouble conditions on output circuits (notification and releasing circuits).

ALARM SILENCED

Yellow LED that illuminates steadily when the ALARM SILENCE switch has been pushed after an alarm.

POWER TROUBLE

Yellow LED that flashes for low or disconnected batteries and earth fault conditions.

BATT

Yellow LED that illuminates steadily on motherboard when battery is low or not detected (not visible through door).

EARTH

Yellow LED that illuminates steadily on motherboard during a ground fault condition (not visible through door).

MICRO FAIL

Yellow LED that illuminates on motherboard when watchdog timer detects microprocessor failure (not visible through door).

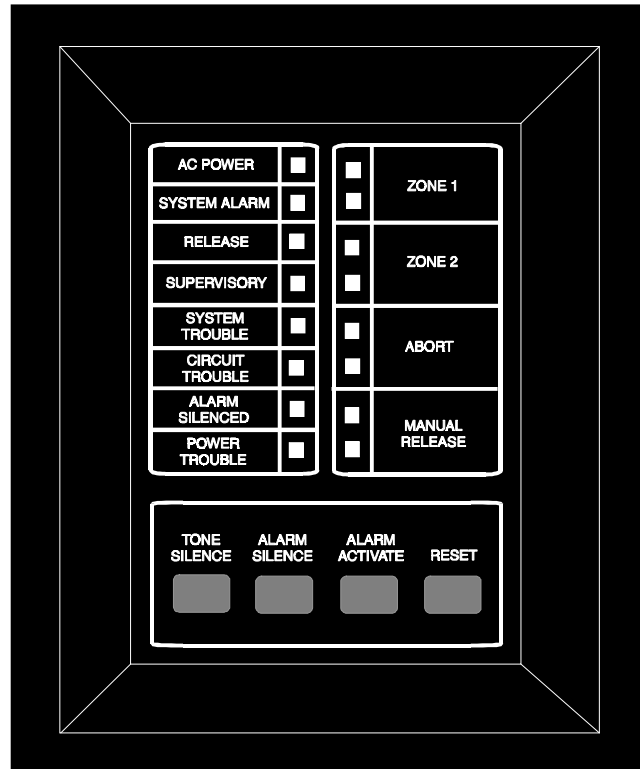

 
BATT EARTH

MICRO
FAIL

2.2 Control Switches

TONE SILENCE

Acknowledge alarms, troubles and supervisories. The panel has alarm and trouble resound with LED flash of new conditions. The flashing trouble LED(s) illuminate steadily on TONE SILENCE and the piezo sounder silences. A Second trouble will resound the piezo. The piezo has three distinct sounds for alarm, trouble, and supervisory. Trouble conditions are self restoring. Alarms latch and require RESET to clear.

ALARM SILENCE

Acknowledge for alarms and supervisories. The ALARM SILENCE switch will silence the local piezo, change any flashing alarm LEDs to steady, and turn off the notification appliance circuits (**not the releasing circuits**). The "ALARM SILENCED" LED will illuminate. Alarm silence is a latching function and requires a RESET to clear.

ALARM ACTIVATE

The ALARM ACTIVATE switch may be used to activate Notification Appliance Circuits. ALARM ACTIVATE also activates the System Alarm relay. ALARM ACTIVATE is a latching function. Pressing ALARM SILENCE silences the notification appliance circuits and System Alarm Relay and lights the Alarm Silenced LED. Pressing RESET returns the system to normal.

SYSTEM RESET

The RESET switch breaks power to all initiating device circuits, 4-wire smoke power and option boards and will clear any activated output circuits. If any alarms or troubles still exist after reset, they will re-activate the panel. Holding RESET down will perform a LAMP TEST function and will activate the piezo sounder.

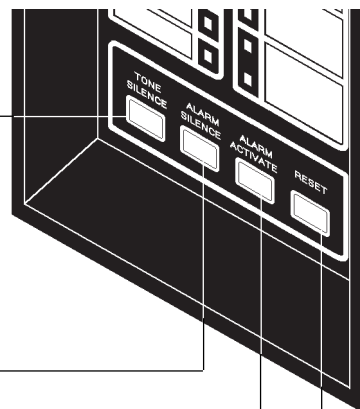

2.3 Zone Status LEDs

The alarm and/or trouble LED(s) will flash until the event(s) has been acknowledged (TONE or ALARM SILENCE), at which point the LED(s) will illuminate steadily.

ALARM LED
TROUBLE LED
ALARM LED
TROUBLE LED
ABORT LED
ABORT TROUBLE LED
MANUAL RELEASE
MANUAL RELEASE TROUBLE LED

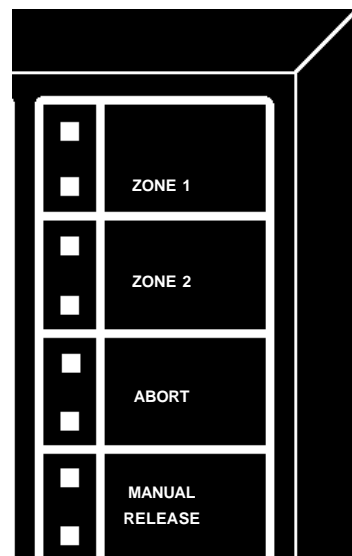

2.4 Supervisory

Output circuit #4 is used as an input for monitoring supervisory devices such as valve tamper switches (note that SW1 DIP switch #2 must be set "ON" -- see section "*Setting MRP-4424 Mode of Operation*"). By setting Switch short circuit on this input (activation of a N.O. contact) will cause the supervisory LED to flash. The piezo sounder will generate a unique sound. TONE SILENCE will silence the piezo and cause the LED to illuminate steadily. Supervisory signals latch and require RESET to clear. An open circuit will be reported as a circuit trouble.

2.5 Zone Disable

If a zone has been disabled, an alarm that occurs on that zone will flash the red zone LED, but neither the piezo nor any output circuit will activate. *If both power sources are removed from the system, all zones will be re-enabled upon restoration of power. Disable status will be lost.*

The Zone Disable routine makes use of the four panel switches as follows:

- 1) Press and hold in the TONE SILENCE switch.
- 2) With the TONE SILENCE switch held in, press (in sequence) the ALARM SILENCE switch, the ALARM ACTIVATE switch, and then the RESET switch.
- 3) The Zone 1 Alarm LED will flash.
- 4) To disable Zone 1, press the RESET switch. The Zone 1 yellow LED will light to show that the zone is disabled.

Note: The RESET switch toggles disable status for the selected zone.

- 5) To select the next zone, press the ALARM SILENCE switch.
- 6) To select the previous zone, press the ALARM ACTIVATE switch.
- 7) When disable selections are complete, release the TONE SILENCE switch.

If any zone has been disabled, the trouble relay will activate and System Trouble LED will flash.

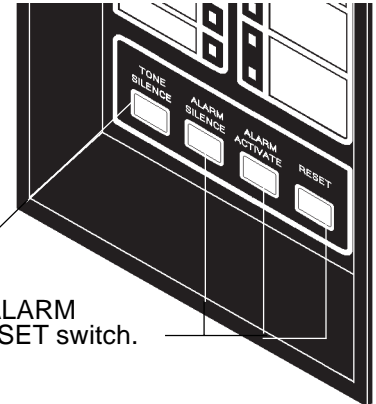

2.6 Last Event Recall

Last Event Recall allows the user to display the previous panel status. The Last Event Recall routine makes use of the four panel switches as follows:

- 1) Press and hold in the TONE SILENCE switch.
- 2) With the TONE SILENCE switch held in, press (in sequence) the RESET switch, the ALARM ACTIVATE switch, and then the ALARM SILENCE switch.
- 3) Last Event is displayed.
- 4) Release the TONE SILENCE switch to return to normal operation.

Note: To clear the last event buffer, press RESET twice.

3.0 Installation Procedure

3.1 General

Carefully unpack the system and check for shipping damage. Mount the cabinet in a clean dry, vibration-free area in which extreme temperatures are not encountered. The location should be readily accessible with sufficient room for easy installation and maintenance. Locate the top of the cabinet approximately five feet above the floor with the hinge mounting on the left. Determine the number of conductors required for the devices to be employed. Pull required conductors into the box through the knockout provided. All wiring should be in accordance with the National and/or Local codes for fire alarm systems.

UL Power Limited Wiring Requirements

Power limited and non-power limited circuit wiring must remain separated in the cabinet. All power limited circuit wiring must remain at least 0.25" away from any non-power limited circuit wiring. Furthermore, all power limited circuit wiring and non-power limited circuit wiring must enter and exit the cabinet through different knockouts and/or conduits. A typical wiring diagram for the MRP-4424 is shown below.

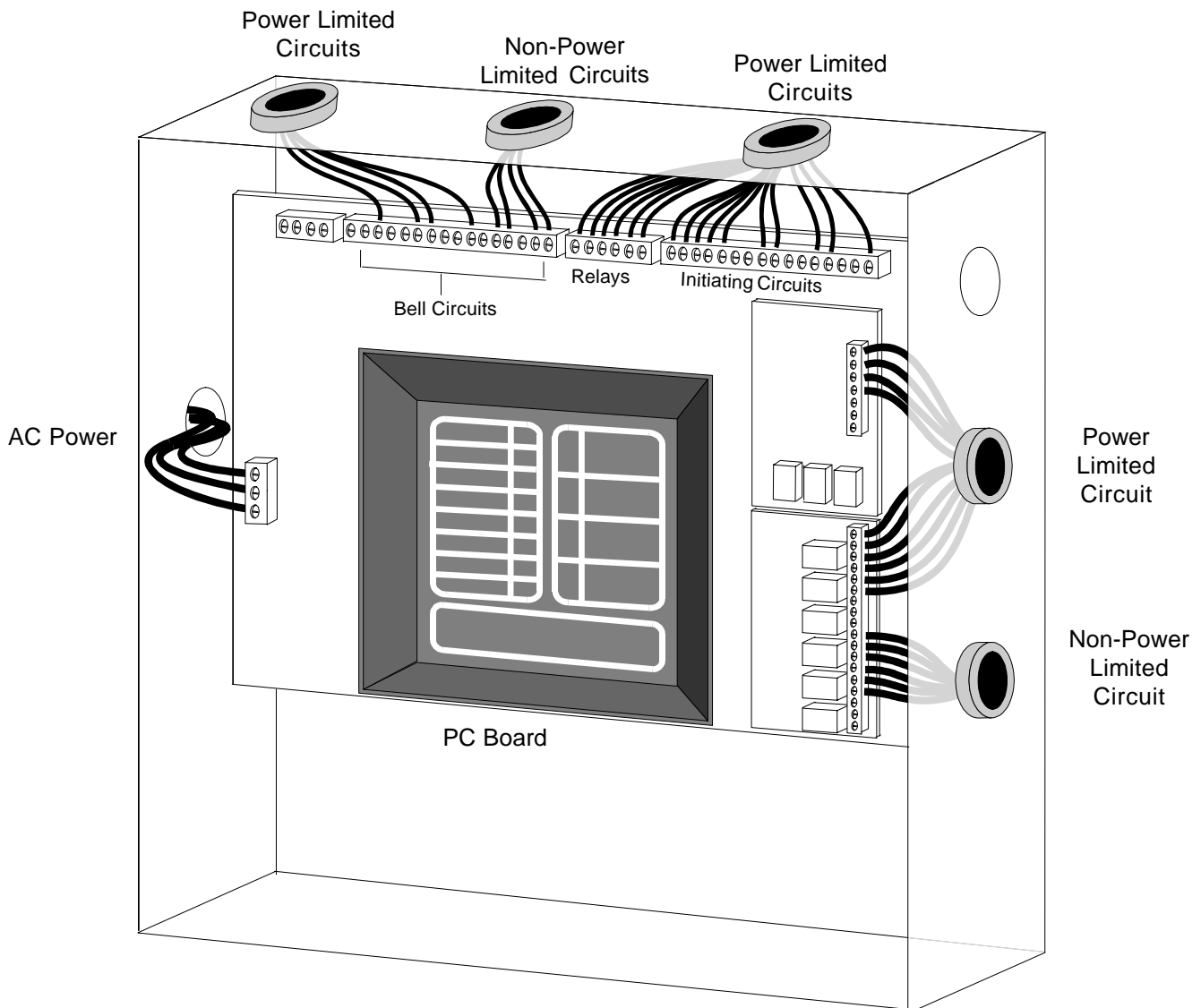

Figure 3.1-1: Typical Wiring Diagram for UL Power Limited Requirements

3.2 Initiating Device Circuits

Zones

Wire all alarm initiating devices sequentially for proper supervision. Initiating devices include: manual pull-stations, heat, photoelectric and ionization type detectors; and waterflow alarm devices. Refer to the Fire•Lite Device Compatibility Chart, for suitable two-wire smoke detectors.

Notes:

- 1) Observe polarity when connecting polarized devices.
- 2) All circuits are supervised and power limited
- 3) Leave Dummy Load (provided) on all unused circuits

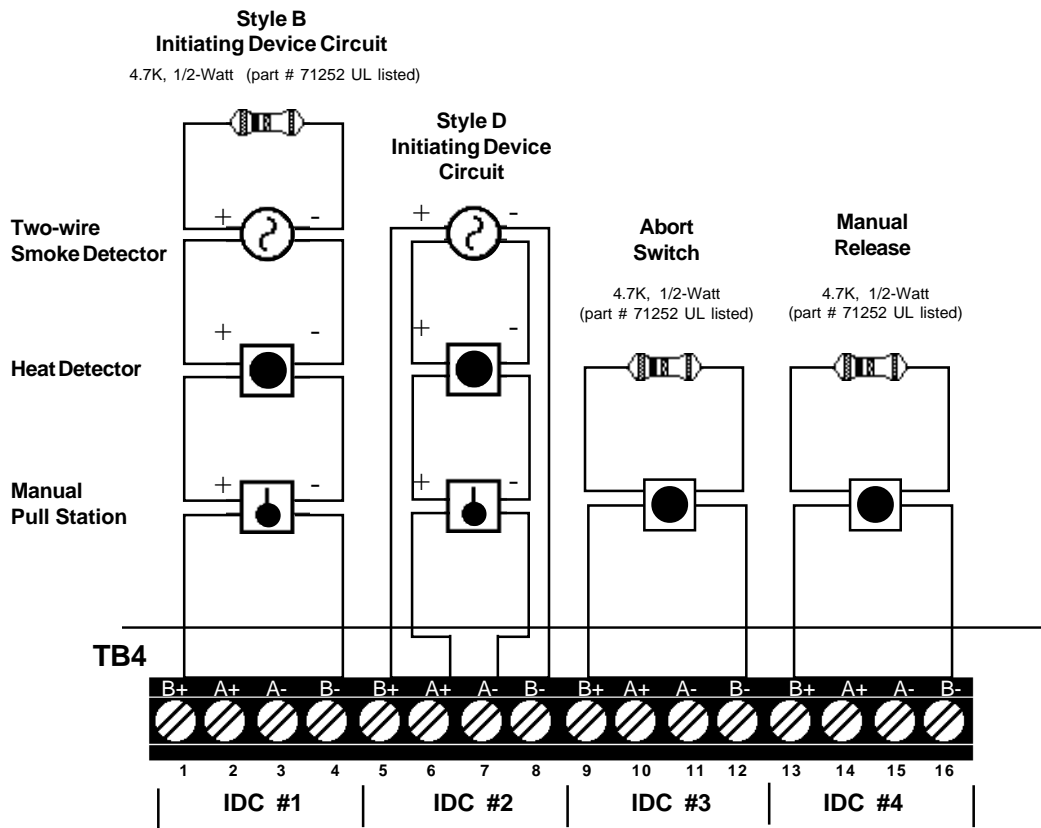
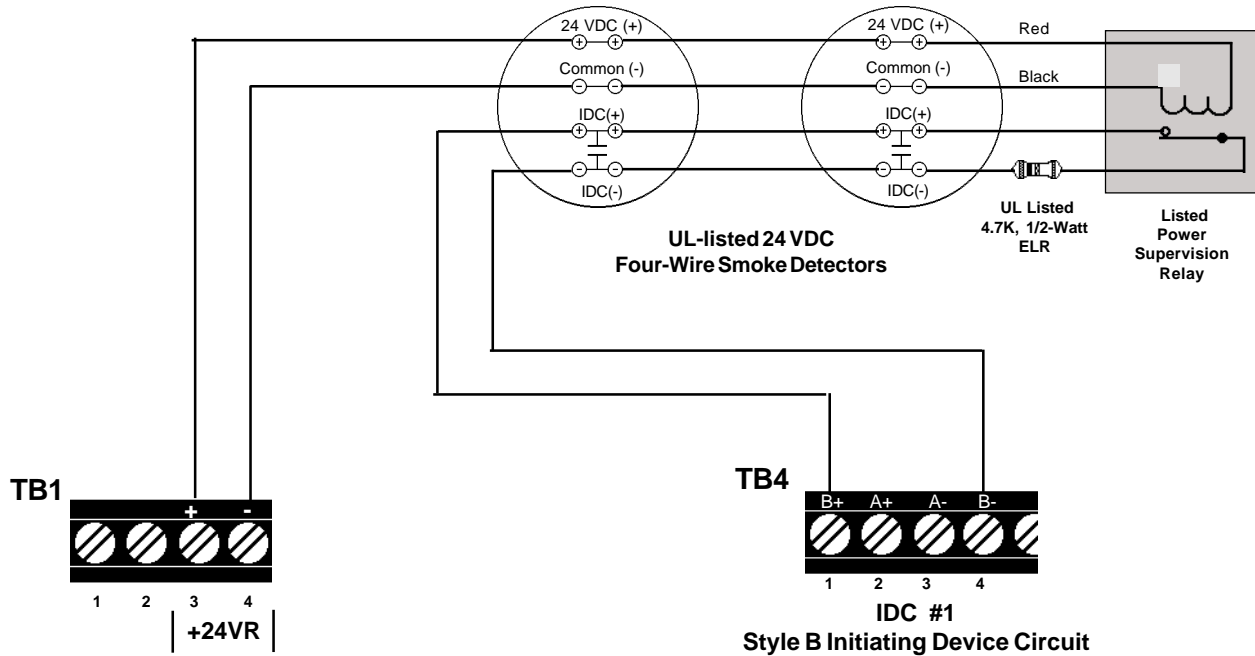

Figure 3.2-1: Example of Initiating Device Circuits

3.3 4-Wire Smoke Detector Connections

Refer to the Device Compatibility Chart for suitable 4-wire smoke detectors.



A maximum of 200mA is available from the +24VDC 4-wire smoke detector power circuit on TB1 terminals 3 and 4. Any power that is drawn from the +24VDC Non-Resettable Power on TB2 terminals 1 and 2 must be subtracted from available 4-wire detector power. (see sections "Specifications" and "Power").

Initiating Device Circuits 1, 2, 3, or 4 can be used. Style D wiring can also be employed.

Figure 3.3-1: Diagram of Connections for a 4-Wire Smoke Detector

Notes on Style B and Style D field wiring:

- 1) The Power Supervision Relay coil leads must be connected to the last detector base 24V screw terminals.
- 2) Calculation of the maximum allowable resistance in the 24VDC detector power wiring:

$$R_{MAX} = \frac{(20.6 - V_{OM})}{(N \times I_s) + (N_A \times I_A) + (I_R)}$$

Where:

R_{MAX} is the maximum resistance of the 24V wires.

V_{OM} is the minimum operating voltage of the detector or end-of-line relay, whichever is greater, in volts.

N is the total number of detectors on the 24V supply loop.

I_s is the detector current in standby.

N_A is the number of detectors on the 24V power loop which must function at the same time in alarm.

I_s is the detector current in alarm.

I_R is the end-of-line relay current.

3.4 Output Circuits

Notification Appliance Circuits

The MRP-4424 can provide two Style Y/Z Notification Appliance Circuits and two Style Y Releasing Circuits (see section "Setting MRP-4424 Mode of Operation" for DIP switch configuration). Each circuit is capable of 1.5 amps of current. Total current drawn from all four circuits cannot exceed 2.25 amps. Refer to the Device Compatibility Chart. Circuits are supervised and power-limited.

Note: Wiring must be configured to maintain a minimum voltage of 20.4V on release circuits. Calculation of maximum allowable resistance:

$$R_{MAX} = \frac{20.6V - 20.4V}{I_s}$$

Where: R_{MAX} = maximum allowable resistance of wiring I_s = solenoid current

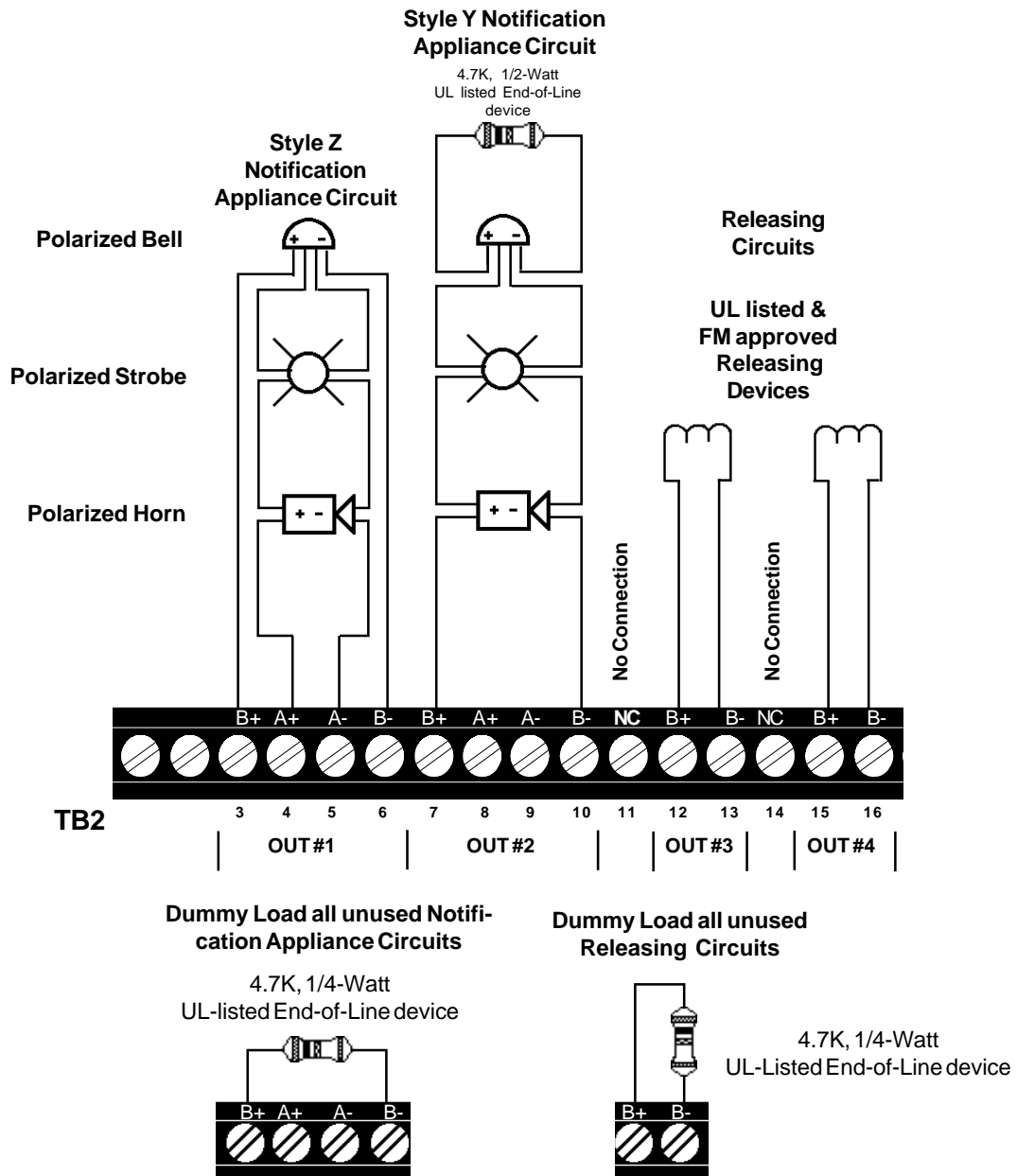

Figure 3.4-1: Notification Appliance Circuits

Alarm Relay

One Form-C dry alarm contact is provided in the basic panel for controlling supplementary devices. It is rated 2 amps at 30 VDC and 0.5 amps at 30 VAC (resistive), and is non-silenceable when an alarm occurs. See below for terminal location.

Trouble Relay

One Form-C dry trouble contact is provided in the basic panel for controlling supplementary devices. It is rated 2 amps at 30 VDC and 0.5 amps at 30 VAC (resistive), and will silence when trouble condition is cleared. See below for terminal location.

Note: The alarm and trouble Form-C dry contact relays must be power limited relays. They must be wired from one of the 24V power limited terminals as shown in the figure below or a comparable UL listed power limited power supply.

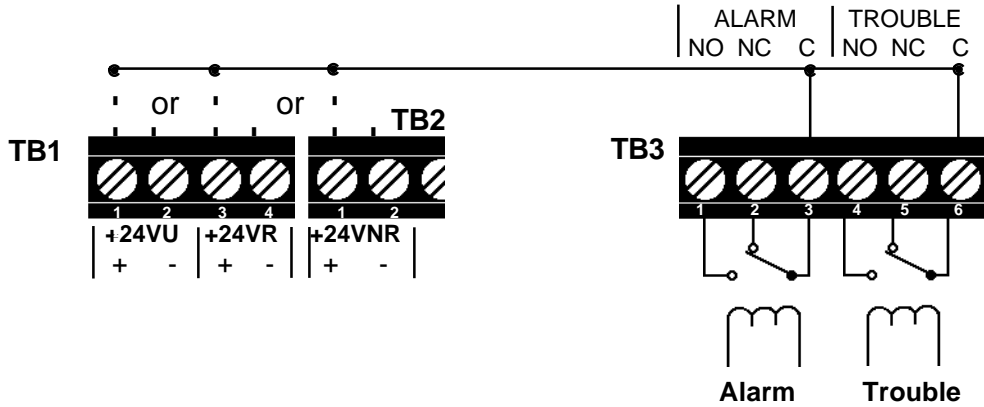

Figure 3.4-2: Alarm / Trouble Coils and Contacts

3.5 Power



CAUTION: Several different sources of power can be connected to this panel. Disconnect all sources of power before servicing. The panel and associated equipment may be damaged by removing and/or inserting cards, modules, or interconnecting cables while this unit is energized.

This output is not suitable for powering devices requiring filtered, regulated DC power.

The combined current draws from the Resettable and Non-Resettable outputs cannot exceed 200 mA.

RMS-Regulated Power
24 VDC power for inductive-type devices such as door holders can be connected to TB1 terminals 1(+) and 2 (-).

4-Wire Smoke Detector Power
24 VDC filtered, regulated, resettable power for 4-wire smoke detectors can be obtained from TB1 Terminals 3 (+) and 4 (-).

Non-resettable Power
24 VDC filtered, regulated, non-resettable power can be drawn from TB2 Terminals 1 (+) and 2 (-).

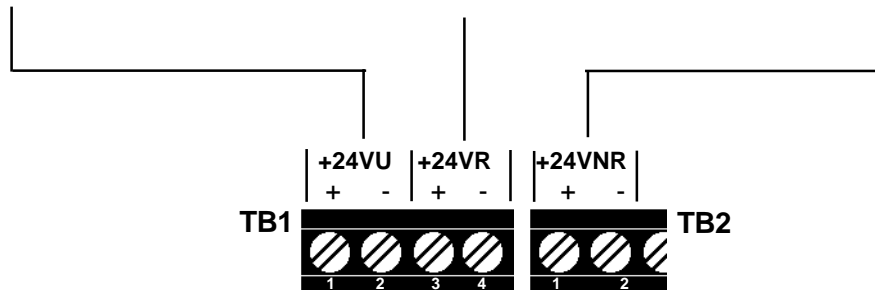

Figure 3.5-1: Diagram of Power Terminals

AC Power

Primary power required for this panel is 120 VAC, 50/60 Hz, 1.2 amps. Overcurrent protection for this circuit must comply with Article 760 of the National Electrical Code (NEC) and/or local codes. Use #14 AWG or larger wire with 600 volt rating.

Battery Power

Observe polarity when connecting battery. Connect battery cable to J9 on the main board using the plug-in connector provided. See Appendix A for calculation of correct battery rating.



CAUTION: Batteries contain sulfuric acid which can cause severe burns to the skin and eyes, and can destroy fabrics. If contact is made with sulfuric acid, immediately flush skin or eyes with water for 15 minutes and seek immediate medical attention.

Voltmeter/Ammeter

To monitor battery voltage and battery charging current, a 4XMMF is required. To install the power meter module, remove the jumper labeled "AMP" and connect cable assembly P2 to pin connector J2 and cable assembly P3 to pin connector J3 on the main board. Secure the 4XMMF to the backbox with the two screws provided.

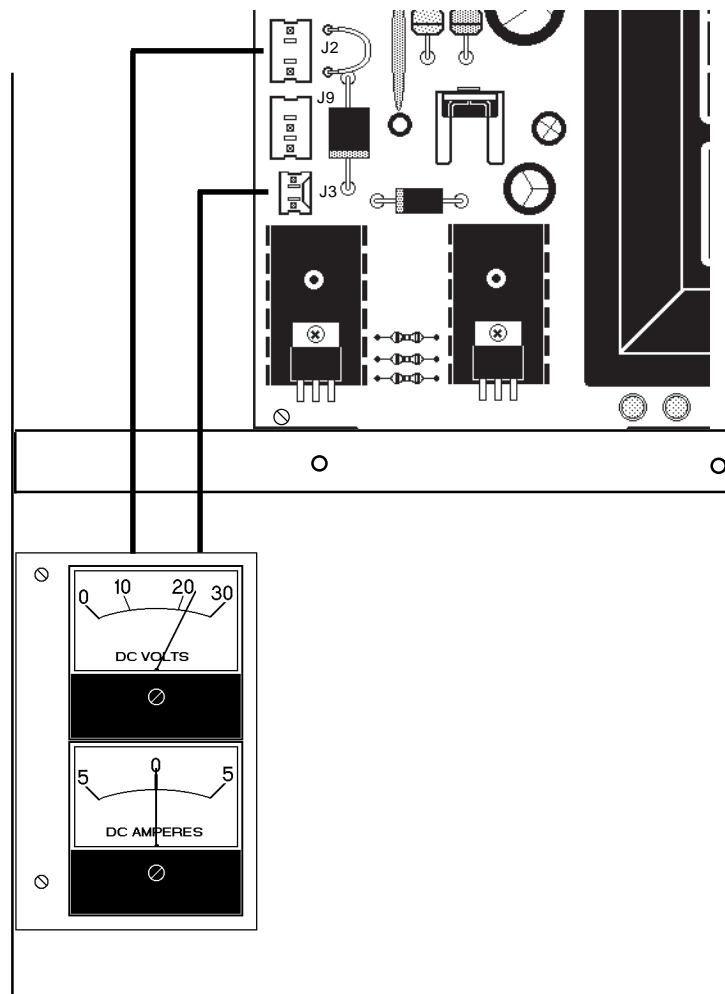

Figure 3.5-2: Diagram of the 4XMMF Voltmeter connected to the Main Board

3.6 Optional Modules

The MRP-4424 has two module connectors - J5 and J8. Three modules are available for the panel and they can be used in any combination, including duplicate modules (see notes below). The corresponding option jumper must be cut before installation of an optional module.

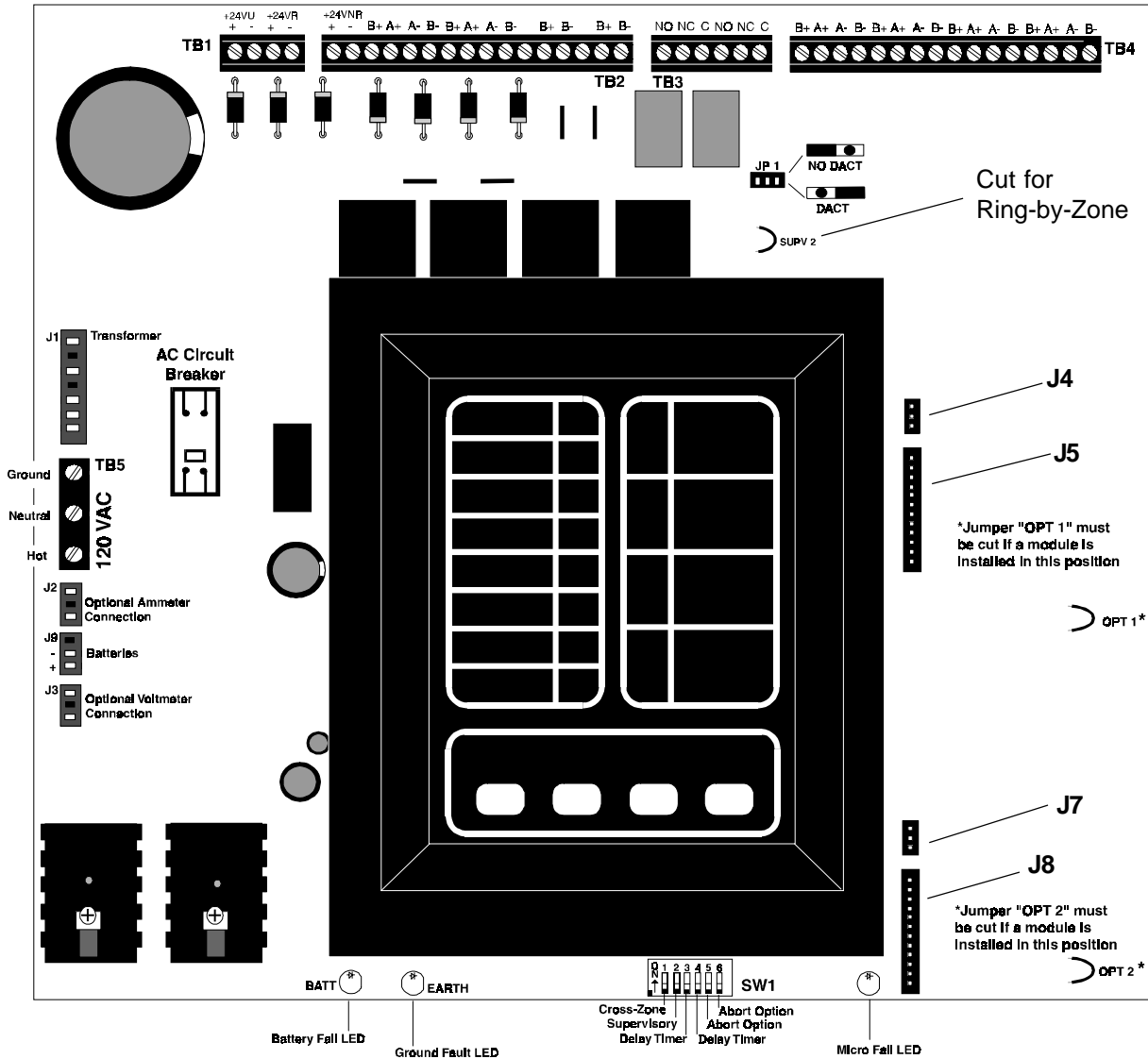

Figure 3.6-1: Option Panel Modules

Notes:

- 1) Optional 4XLMF module for an RZA-4XF Annunciator must be installed on J7 and J8 only.
- 2) 4XTMF and 4XZMF modules can be installed in either location.

Installing Option Modules

Insert the two stand-offs (provided) into the holes located on the right-side edge of the main board. Carefully align the pins on the main board with J1 and/or J2 on the option board. Insert screws (provided) into the holes on the top of the stand-offs. Affix the terminal identification labels provided with the option modules as shown below.

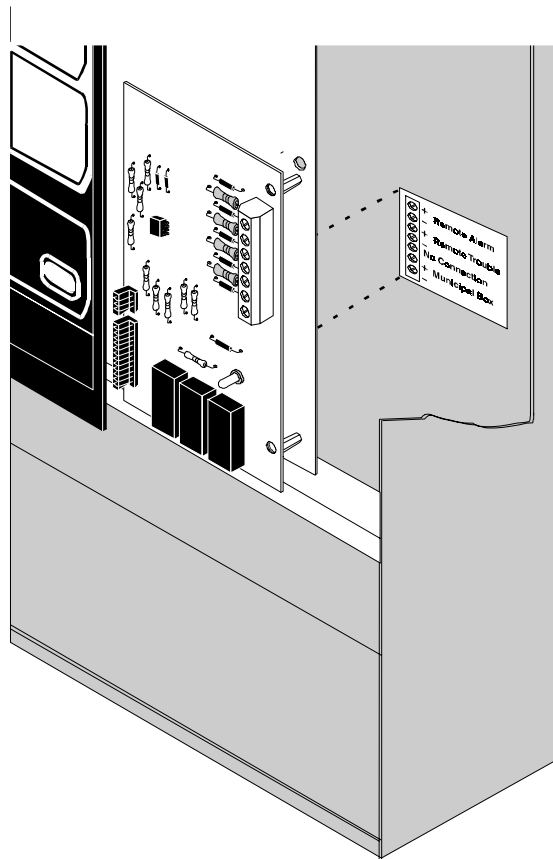
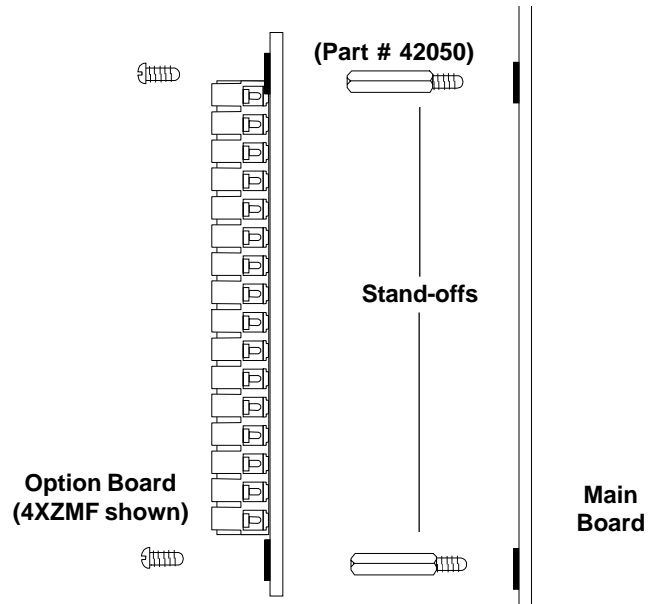
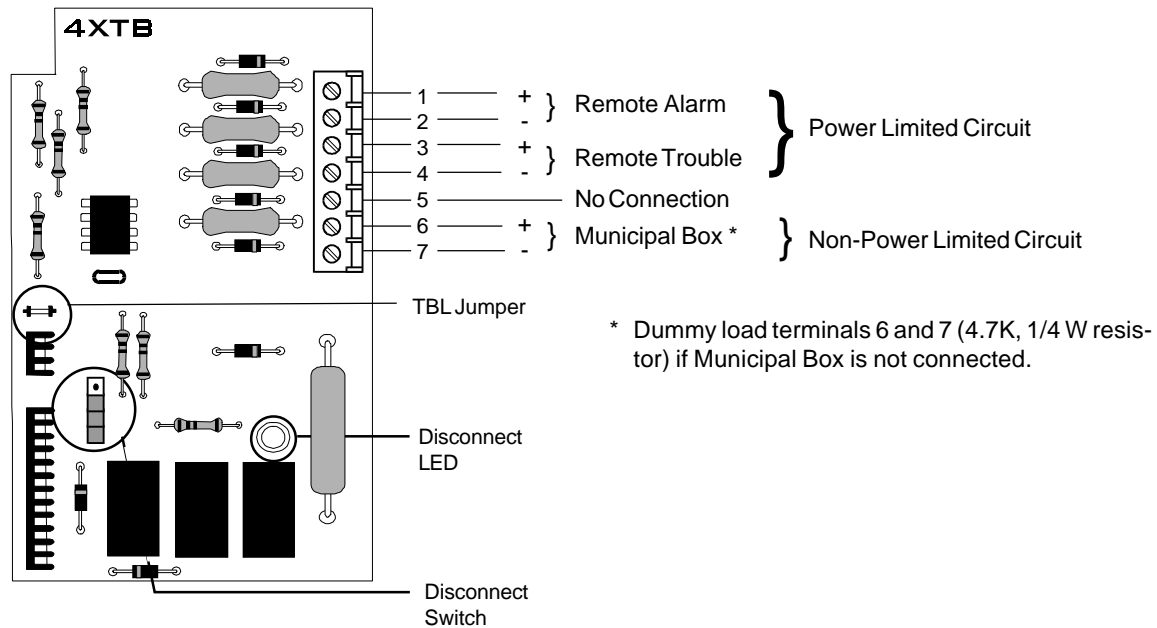

Figure 3.6-2: Installing Option Modules

Transmitter Module -- 4XTMF

Polarities shown in activated positions. The wiring of this module must follow the requirements as specified in the "General" section, "UL Power Limited Wiring Requirements."



Push the disconnect switch down to prevent unwanted activation of the Municipal Box during testing of the control panel. The Disconnect LED will remain illuminated while the Municipal Box is disconnected. The System Trouble LED will indicate disconnected and/or Open Circuit conditions on the Municipal Box. *Cutting the TBL jumper will allow the alarm reverse polarity circuit to open on trouble, if no alarm exists.*

Note: Remote Alarm, Remote Trouble and Municipal Box wiring can leave the building.

Zone Relay Module -- 4XZMF

Non-power limited and power limited wiring must have a minimum distance of 0.25" wire to wire. If this module is used to drive non-power limited and power limited circuits, please follow the instructions below:

Relay #1 through #4 will activate with Output #1 through #4 and remain latched unless jumper "LATCH" is cut.

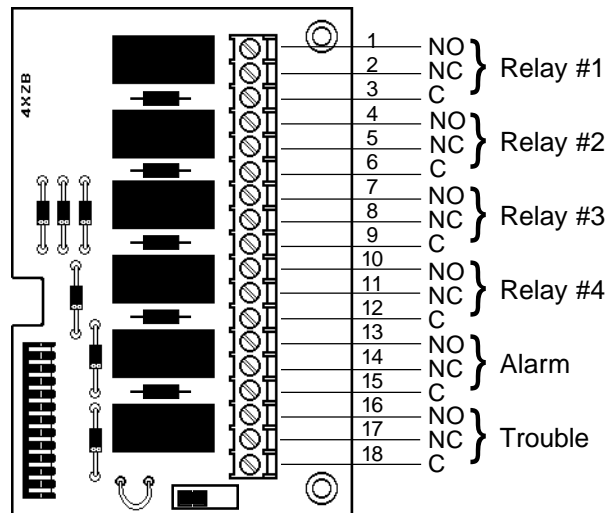

Use Disable switch to disconnect the relays

Cut jumper for non-latching (silenceable) relay operation

1) Skip a set of dry contacts to maintain the 0.25" required space between power limited and non-power limited circuits. The wiring of this module must follow the requirements as specified in the "General" section, "UL Power Limited Wiring Requirements."

OR

2) If this module is needed to drive power limited and non-power limited relays that are next to each other, refer to the figure below showing a typical connection:

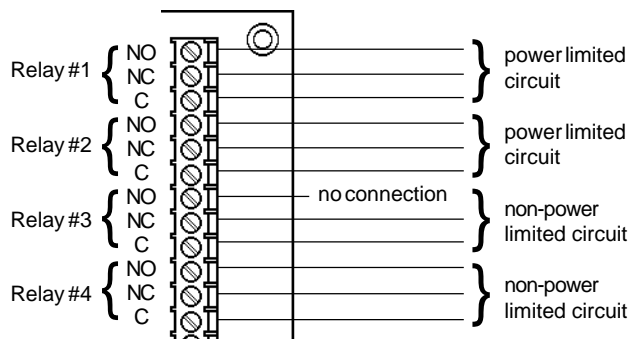

Note: Refer to the Protected Premises Unit label, located on the door of the control panel, to indicate if any dry contacts are to be used as non-power limited dry contacts.

LED Interface Module -- 4XLMF

The wiring of this module must follow the requirements as specified in the "General" section, "UL Power Limited Wiring Requirements."

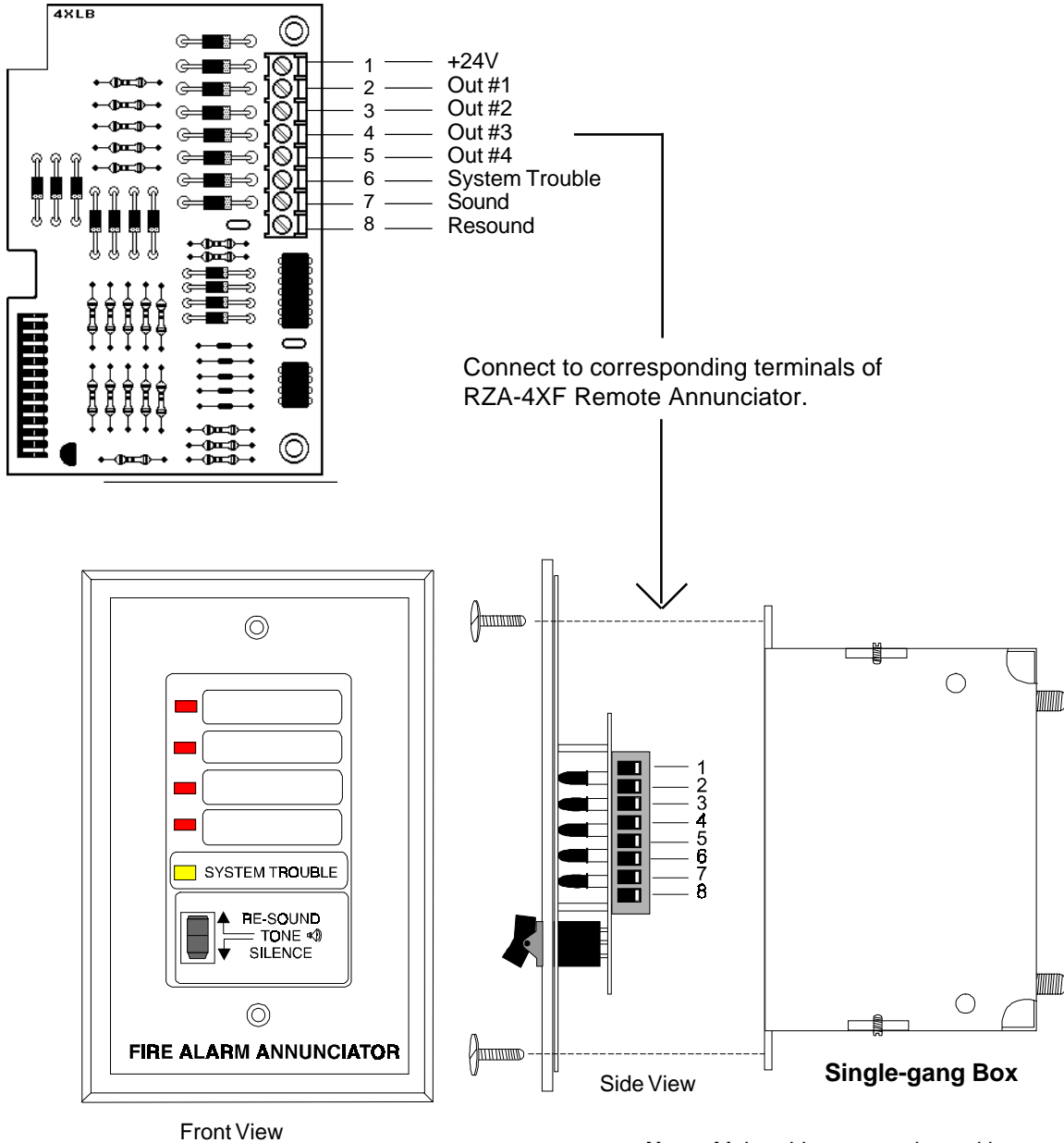

Note: Make wiring connections with system power off. Maximum wire impedance is 50 ohm per wiring connection.

Figure 3.6-3: LED Interface Module -- 4XLMF

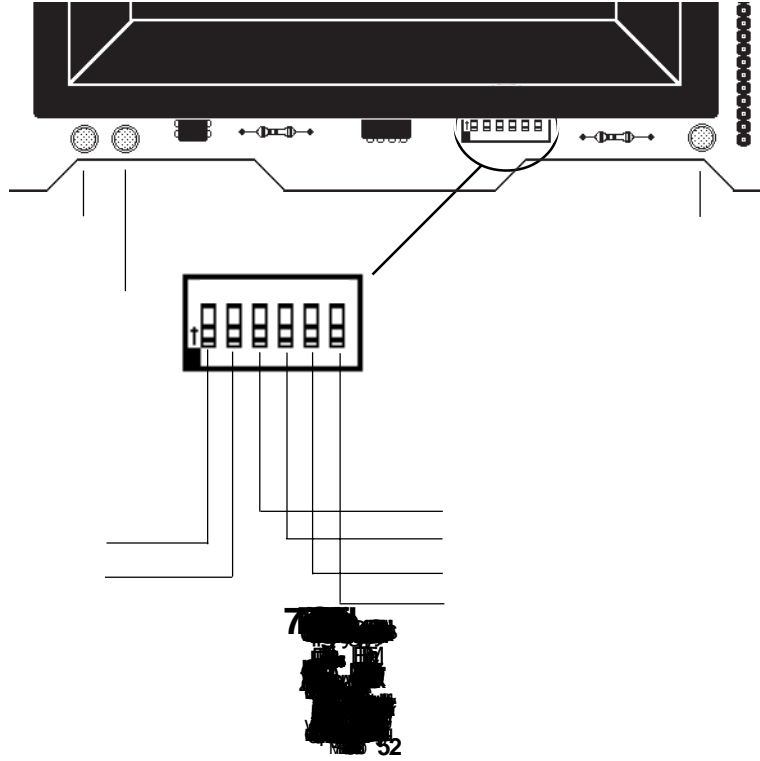



--	--

--	--	--	--



62



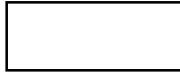



92

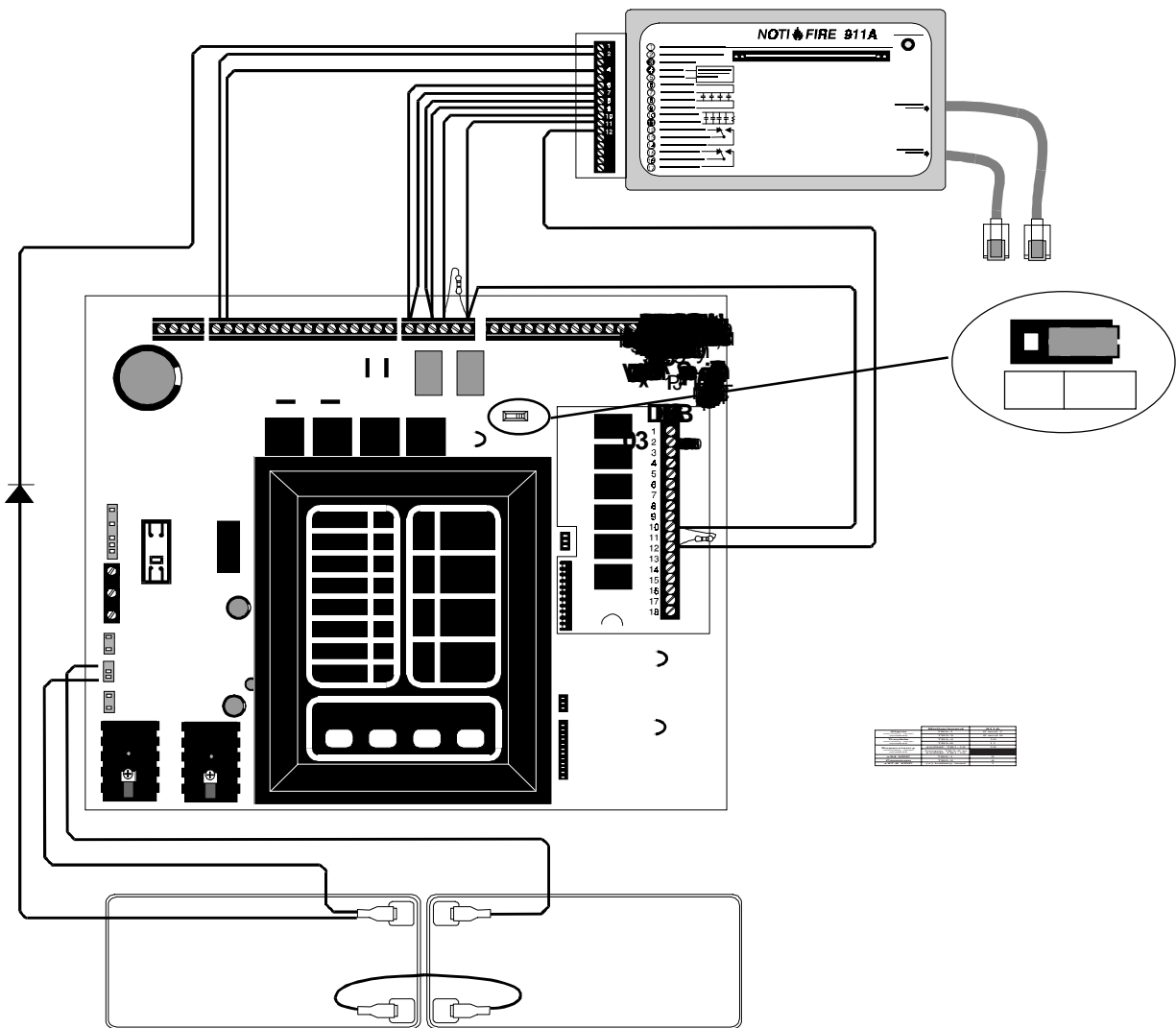

Figure B-1B: NFPA 72-1993 Signaling Systems for Central Station Service (Protected Premises Unit) and Remote Station Fire Alarm System (Protected Premises Unit)

NOTI-FIRE 911AC DACT* - for connection to a Central Station Receiver or Protected Premises Receiving Unit. This unit must be installed as illustrated below. For additional information on the 911AC, refer to document 74-06200-005.

All connections between the FACP and 911AC must be in conduit, less than 20' in length in the same room.
*** This application using the NOTI-FIRE 911AC is not FM approved.**

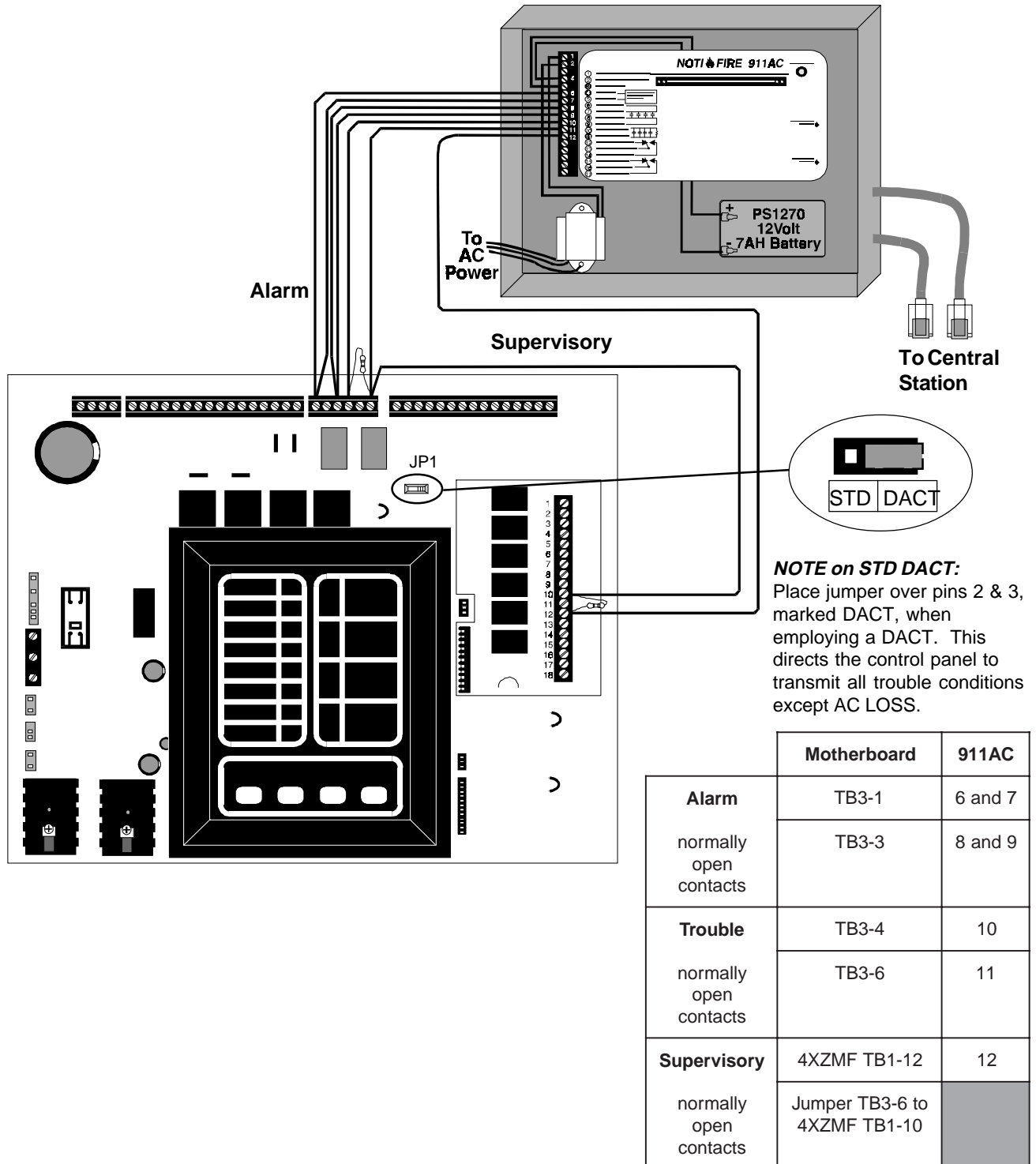
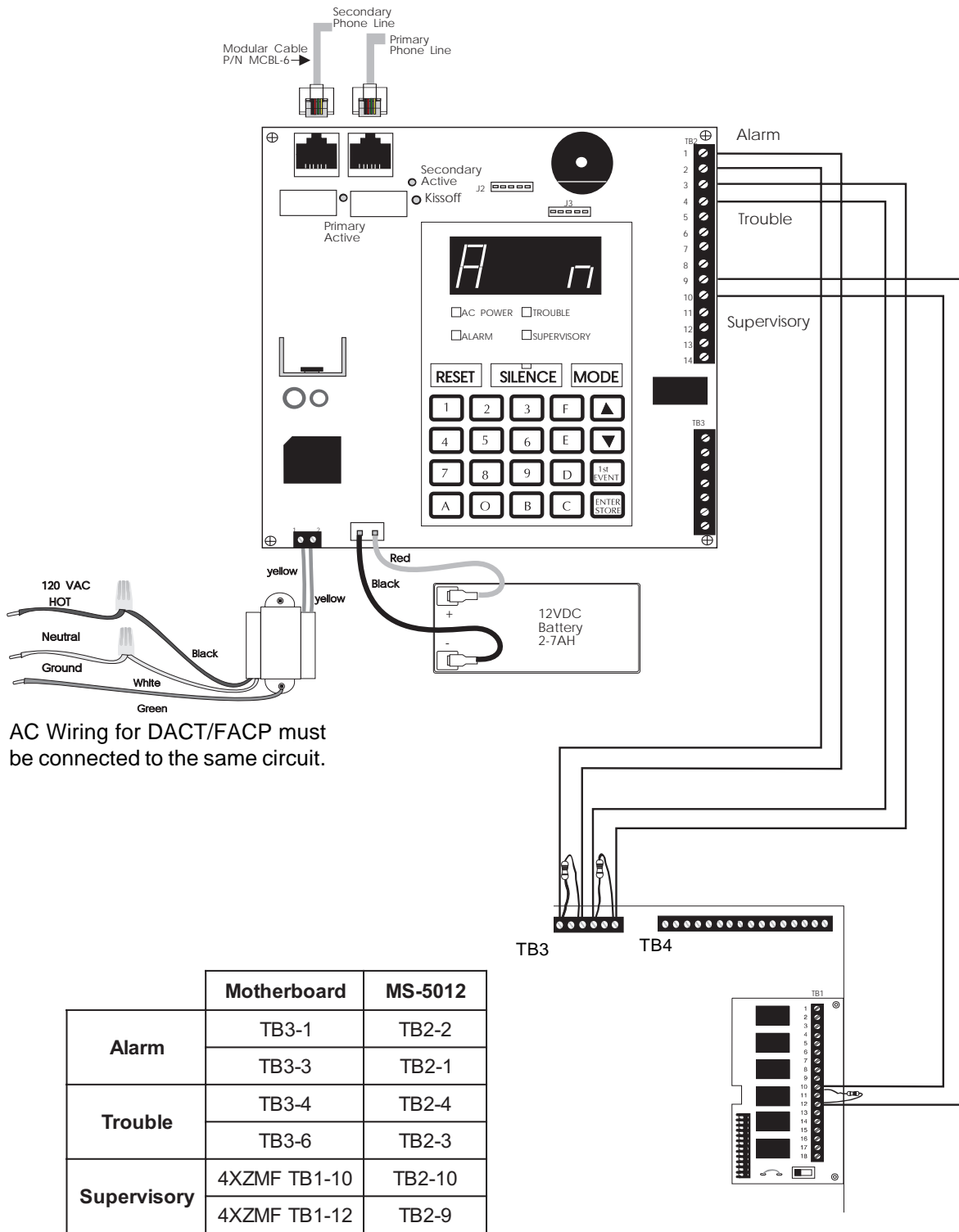

Figure B-1C: Using the MS-5012 as a Slave Communicator

- 1) Reference the MS-5012 manual, for additional information.
- 2) Program the MS-5012 for slave applications.



AC Wiring for DACT/FACP must be connected to the same circuit.

Figure B-2: NFPA 72-1993 Auxiliary Fire Alarm System

All connections are power limited and supervised. This application is not suitable for separate transmission of sprinkler supervisory or trouble conditions.

Note: Maximum loop resistance allowed for wiring from control panel to Municipal Box is 3 ohms.

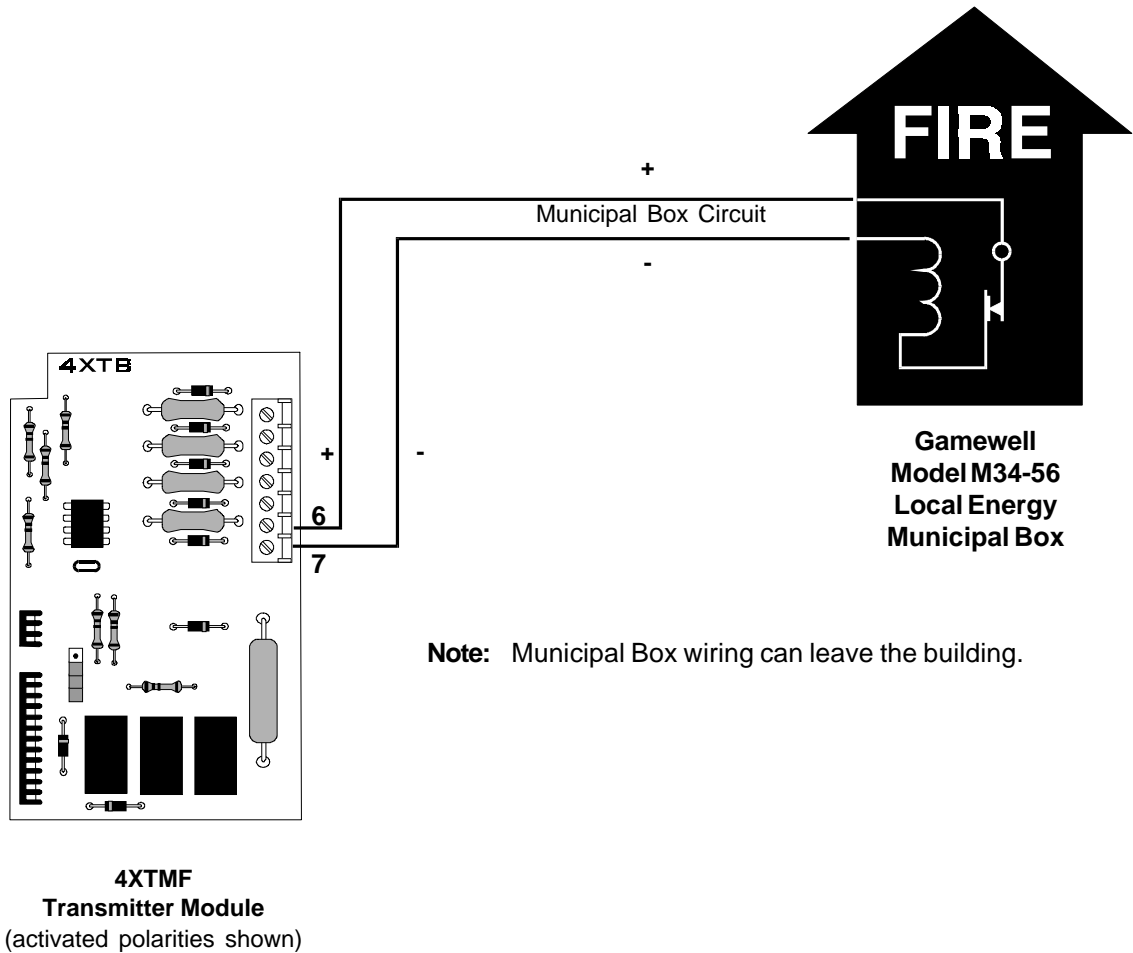

Figure B-3: NFPA 72-1993 Remote Station Fire Alarm System

Intended for connection to a polarity reversal circuit of a remote station receiving unit having compatible ratings. All connections are power limited and supervised with the exception of the reverse polarity loop. Supervision of the loop is the responsibility of the receiver.

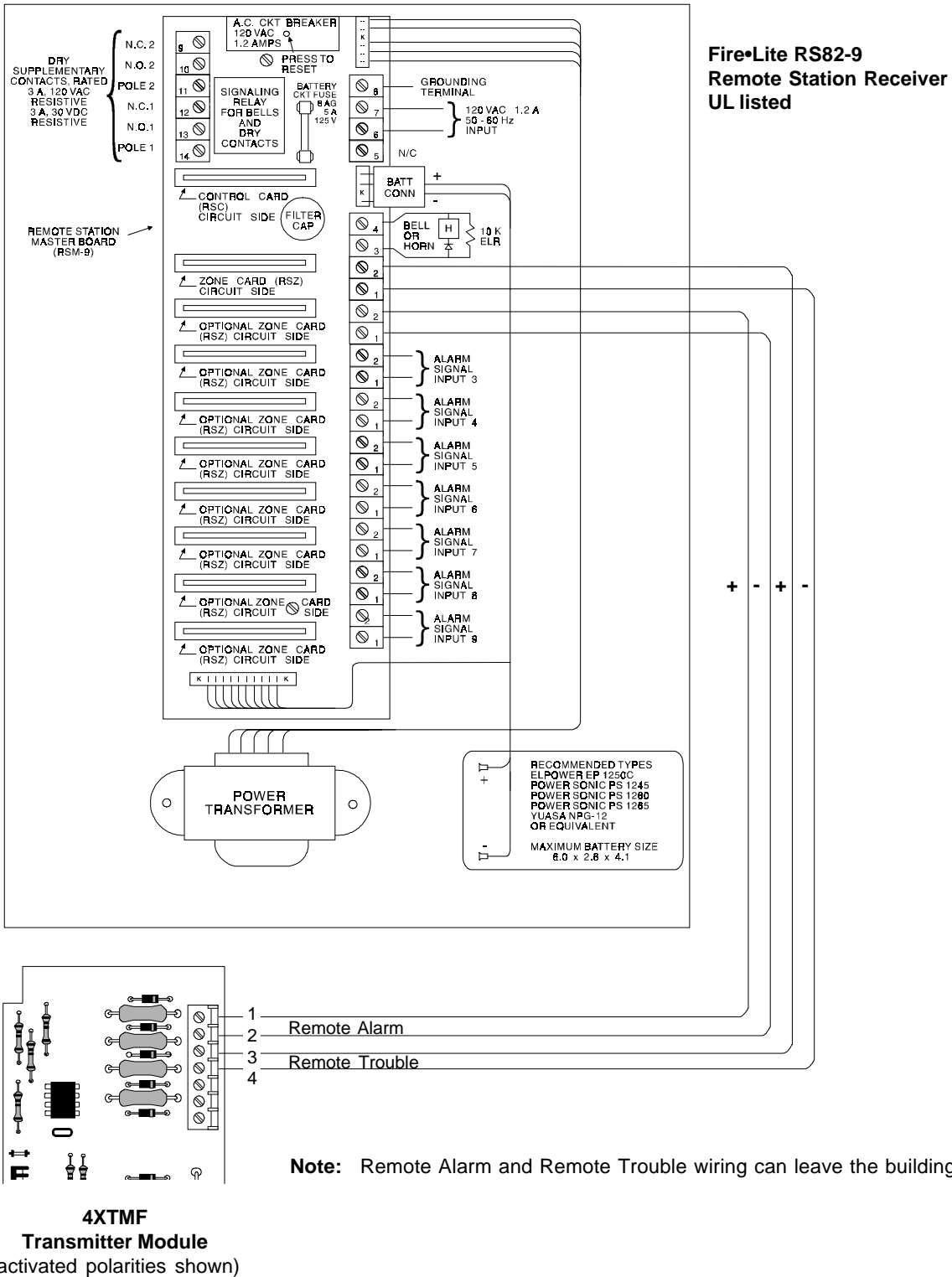
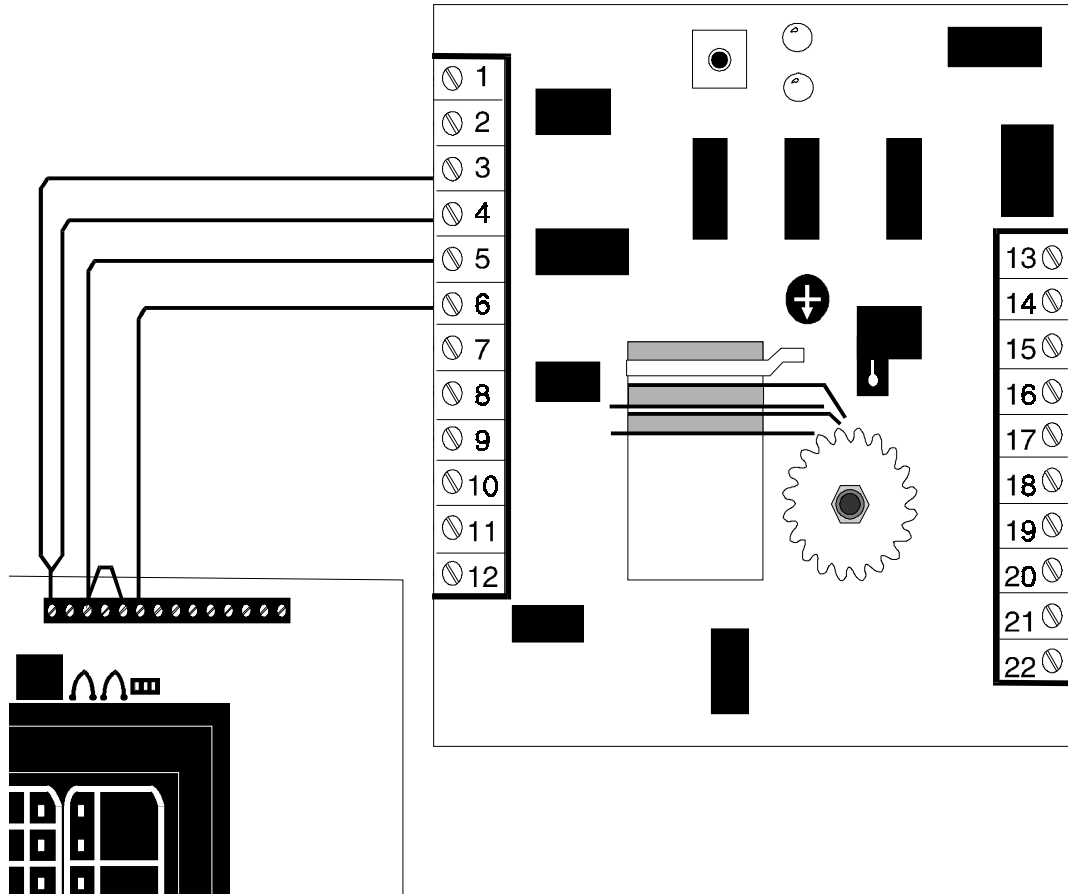

Figure B-4: NFPA 72-1993 Proprietary Fire Alarm System

* This application using the Potter EFT-C is pending FM approval.

Notes:

- 1) Connection between control panel and the transmitter are supervised by the transmitter.
- 2) Use transformer model ULT STK. NO. 1000391 (listed, Class 2, 12 V, 10 VA.). See Potter Electric Signal Company Bulletin # 748.
- 3) This control panel/transmitter arrangement can be employed for NFPA 72-1993 Proprietary Fire Alarm Systems.



Notes:

- 1) Form-C Alarm contact programmed to activate on General Alarm.
- 2) Form-C Trouble contact which will automatically activate on any Trouble condition.

Trouble Shooting Table

SYMPTOM		PROBLEM		SOLUTION	
AC Power LED on	System trouble LED on	Circuit trouble LED on	Notification appliance circuit trouble	<ol style="list-style-type: none"> 1. Check TB2 for proper connections.(TB3 for 4XB panels) 2. Remove all field wiring and install dummy ELR at output circuit. Check for supervisory voltage across it, (Normal -2.3 V), if problem persists, replace circuit board. 3. Removed dummy ELR, reconnect field wiring and measure voltage across output; (trouble -5V, short 0V). 4. Check for ELR at last device. 5. Check field wiring. 	
		Any of the right column yellow LEDs flashing	Initiating zone open circuit trouble	<ol style="list-style-type: none"> 1. Check TB4 for proper connections. 2. Remove field wiring for zone in trouble and install dummy ELR (4.7K for 24V; 2.2K for 12V). If problem persists, replace circuit board. 3. Check for ELR at last device. 4. Check field wiring. 	
		Any of the right column yellow LEDs steady on	Zone disable	1. Check installation manual.	
		Power trouble LED on	Battery trouble Batt yellow LED on	Missing or Disconnected	1. Check battery connections.
				Low or damage battery	<ol style="list-style-type: none"> 1. Remove batteries, check voltage across charger output (17 to 19V for 24V; 8-10V for 12V), otherwise replace circuit board. 2. Reconnect batteries, measure battery voltage at battery terminals. If voltage is less than 85% of rated voltage, allow them to charge for 48 hours. 3. If problem persists, replace batteries.
	Yellow LED on 4XTM on	Ground fault trouble Earth yellow LED on	<ol style="list-style-type: none"> 1. Remove field wiring from main panel and optional module(s) (if installed). Install dummy ELR (4.7K for 24V; 2.2K for 12V). 2. Remove both battery leads. 3. If trouble clears, connect one circuit at the time to pin point the problem. 4. If trouble doesn't clear, replace circuit board. 		
			4XTM	1. Move Municipal Box disconnect switch SW1 up.	
			OPT1, OPT2 jumper cut	1. Install optional module(s) or replace jumper if module(s) is not used.	
			Municipal Box open circuit	<ol style="list-style-type: none"> 1. Install dummy load if Municipal Box option isn't used. 2. Check Municipal Box wiring. 	
	Any of the right column red LEDs on		Short on initiating circuit wiring	1. Remove field wiring and install ELR. If trouble clears, look for faulty or incorrectly wired devices.	
	Disconnecting Municipal Box switch on 4XTM does not create a trouble		Jumper for optional modules isn't cut	1. Cut associated jumper OPT1 or OPT2.	
	4XZM: associated LED doesn't activate for alarm, trouble or supervisory conditions		Optional module trouble	<ol style="list-style-type: none"> 1. Make sure module is properly installed. 2. Move disable switch SW1 on 4XZM to the left. 	
	RZA-4X piezo doesn't sound for alarm, trouble or supervisory conditions		4XLM	<ol style="list-style-type: none"> 1. Make sure that 4XLM module is installed on J7 and J8. 2. Check field wiring. 	
	Micro Fail yellow LED on		Microprocessor damaged	1. Replace circuit board.	
	All RZA-4X LEDs stay on		Power wasn't removed prior installation	1. Press system reset.	
AC Power LED off	System trouble LED on	Loss of main power	1. Check incoming power (TB5). (TB1 for 4XB panels)		
		Damaged circuit breaker	1. Replace circuit board.		
	Micro Fail yellow LED on	Microprocessor damaged	1. Replace circuit board.		

NOTES

NOTES

NOTES

Limited Warranty

Fire-Lite® warrants its products to be free from defects in materials and workmanship for eighteen (18) months from the date of manufacture, under normal use and service. Products are date stamped at time of manufacture. The sole and exclusive obligation of **Fire-Lite®** is to repair or replace, at its option, free of charge for parts and labor, any part which is defective in materials or workmanship under normal use and service. For products not under **Fire-Lite®** manufacturing date-stamp control, the warranty is eighteen (18) months from date of original purchase by **Fire-Lite®**'s distributor unless the installation instructions or catalog sets forth a shorter period, in which case the shorter period shall apply. This warranty is void if the product is altered, repaired or serviced by anyone other than **Fire-Lite®** or its authorized distributors or if there is a failure to maintain the products and systems in which they operate in a proper and workable manner. In case of defect, secure a Return Material Authorization form from our customer service department. Return product, transportation prepaid, to **Fire-Lite®**, 12 Clintonville Road, Northford, Connecticut 06472-1653.

This writing constitutes the only warranty made by **Fire-Lite®** with respect to its products. **Fire-Lite®** does not represent that its products will prevent any loss by fire or otherwise, or that its products will in all cases provide the protection for which they are installed or intended. Buyer acknowledges that **Fire-Lite®** is not an insurer and assumes no risk for loss or damages or the cost of any inconvenience, transportation, damage, misuse, abuse, accident or similar incident.

Fire-Lite® GIVES NO WARRANTY, EXPRESSED OR IMPLIED, OF MERCHANTABILITY, FITNESS FOR ANY PARTICULAR PURPOSE, OR OTHERWISE WHICH EXTEND BEYOND THE DESCRIPTION ON THE FACE HEREOF. UNDER NO CIRCUMSTANCES SHALL **Fire-Lite®** BE LIABLE FOR ANY LOSS OF OR DAMAGE TO PROPERTY, DIRECT, INCIDENTAL OR CONSEQUENTIAL, ARISING OUT OF THE USE OF, OR INABILITY TO USE **Fire-Lite®** PRODUCTS. FURTHERMORE, **Fire-Lite®** SHALL NOT BE LIABLE FOR ANY PERSONAL INJURY OR DEATH WHICH MAY ARISE IN THE COURSE OF, OR AS A RESULT OF, PERSONAL, COMMERCIAL OR INDUSTRIAL USE OF ITS PRODUCTS.

This warranty replaces all previous warranties and is the only warranty made by **Fire-Lite®**. No increase or alteration, written or verbal, of the obligation of this warranty is authorized.

"**Fire-Lite**" is a registered trademark.



Fire-Lite® ALARMS
INCORPORATED

12 Clintonville Road, Northford, CT 06472
Phone: (203) 484-7161
FAX: (203) 484-7118